

TIME FOR INSTALLATION

30 MINS. - 1 HOUR

# RCI OFFROAD

EASY



BASIC SKILLS  
REQUIRED

## 18+ Jeep Wrangler JL/JLU Rear Differential Skid Plate Installation Guide

Contact RCI: [SALES@RCIOFFROAD.COM](mailto:SALES@RCIOFFROAD.COM)  
(970) 797-3089

Part Number	Description	Qty:
SM-01291	18+ JLU Rear Differential Skid	1
SM-01293	JLU Rear Differential Top Bracket	1
SM-01292	JLU Rear Differential Bottom Bracket	1
SM-00001	Universal Axle Upper Mount	1
HK-00049	Universal Differential Hardware Kit:	1
HW-00052	3/8 x 1" Carriage Bolt GR-5	4
HW-00026	3/8 USS Flat Washer Thru Hard	8
HW-00029	3/8 Split Lock Washer Zinc	8
HW-00035	3/8 x 1.5" Carriage Bolt	4
HW-00030	3/8-16 FIN Hex Nut GR-5 Zinc	8

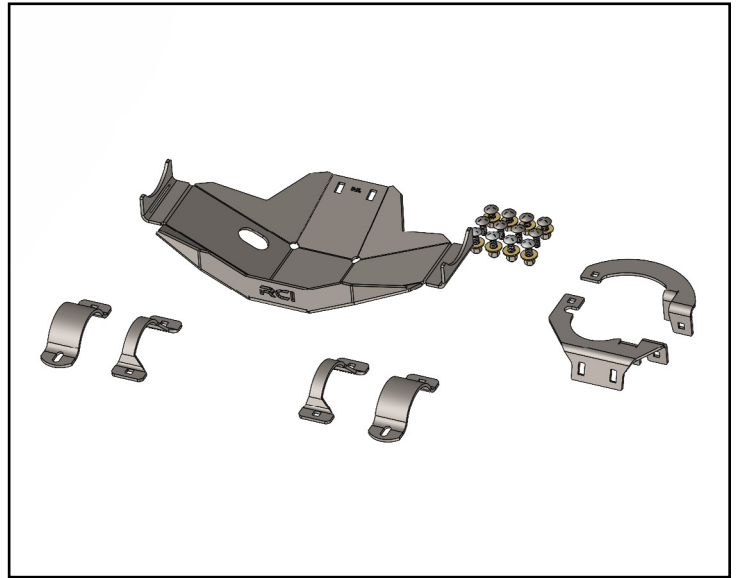
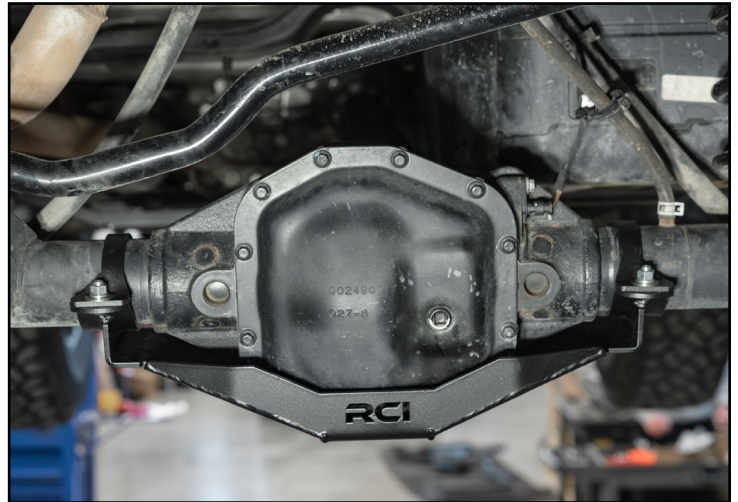

**Caution:** Use hand tools, impact wrenches may cause damage if over torqued.

**Read the entire notes and instructions before installation.**

# Installation Notes

## Installation Notes:

**RH** refers to the passenger side of the vehicle.

**LH** refers to the driver side of the vehicle.

Always use the proper torque specifications.

If applicable to this installation, torque specifications will be listed throughout the document.

Please read all of these instructions and familiarize yourself with the complete process **BEFORE** you begin.

## General Safety:

Park your car in a safe, well lit, level area.

Shut the engine off and remove the key from the ignition switch.

Make sure any remote start devices are properly disabled.

**ALWAYS** wear safety glasses.

Make sure the parking brake is applied until the vehicle is safely lifted and supported.

Whether lifting a vehicle using an automotive lift or a hydraulic jack, utilize the factory specified lift points.

Lifting a vehicle in an incorrect location can cause damage to the suspension/running gear.

**ALWAYS** support the vehicle with properly rated jack stands.

**ALWAYS** read and follow all safety information and warnings for the equipment you are using.

## Required Tools:

1/4", 3/8" & 1/2" Socket Sets & Ratchets

Floor Jack

Jack Stands

Combination Wrench Set

Plier Set

Torque Wrenches

## Installation Overview:

Before installation, remove all components and hardware from their packaging and verify that all the components are present.

## Section 1: Installing the New Skid Plate

### Step #1

Remove all components and hardware from their packaging and verify that all the components are present.

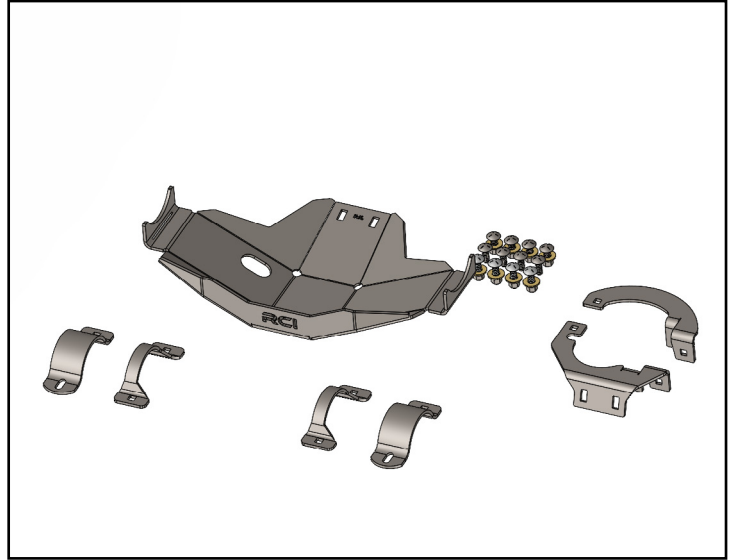

### Step #2 | Floor Jack -OR- Pole Jack

Support the rear differential skid plate from underneath and lift the skid plate into place.



## Section 1: Installing the New Skid Plate

### Step #3

Place the upper axle clamps (arrows) onto the rear axle housing and align the mounting hole locations on the upper bracket with the bottom mounting bracket as shown.

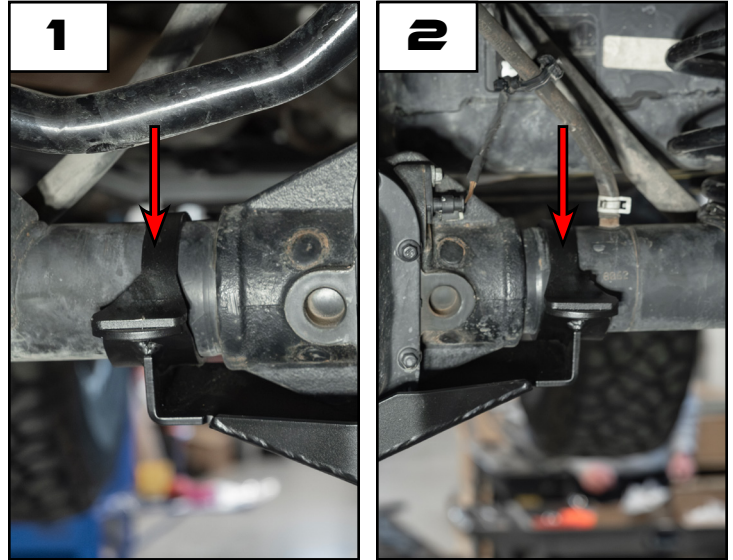

### Step #4 9/16" Socket & Ratchet

Loosely install the provided 3/8" x 1" carriage bolts, flat washers, split-lock washers and hex nuts (arrows) to secure the rearmost mounting locations on the axle clamps.



## Section 1: Installing the New Skid Plate

### Step #5 9/16" Socket & Ratchet

Loosely install the provided 3/8" x 1.5" carriage bolts, flat washers, split-lock washers and hex nuts (arrow) to secure the frontmost mounting locations on the axle clamps.

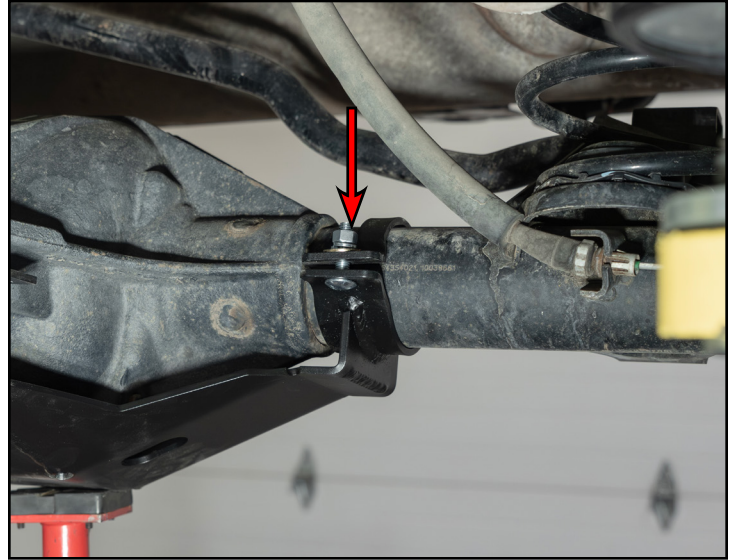

### Step #6 9/16" Socket & Ratchet

Loosely install the lower pinion clamp bracket to the rear differential skid plate and secure it using the provided 3/8" x 1" carriage bolts, flat washers, split-lock washers and hex nuts (circled in **YELLOW**).



## Section 1: Installing the New Skid Plate

### Step #7 9/16" Socket & Ratchet

Loosely install the upper pinion clamp (highlighted in **GREEN**) with the provided 3/8" x 1" carriage bolt, flat washer, split-lock washer and hex nut (arrow).

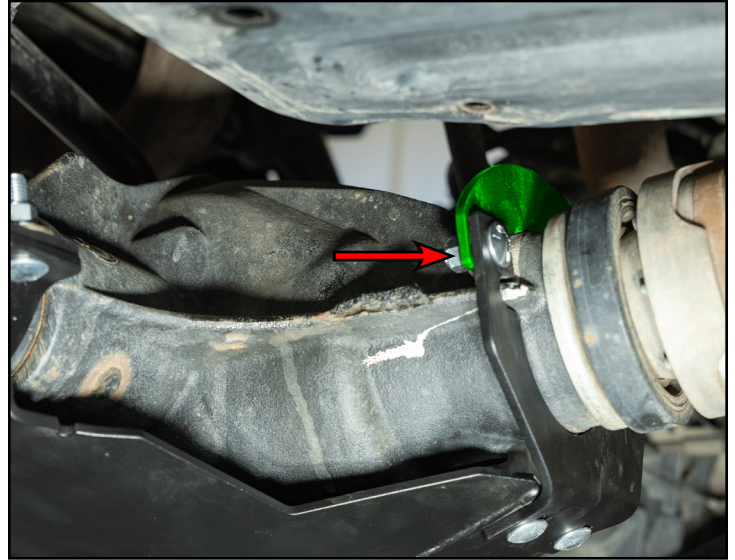

### Step #8 9/16" Wrench

Ensure the tab (arrow) rests on top of the casting of the rear differential housing. Loosely install the upper pinion clamp with the provided 3/8" x 1.5" carriage bolt, flat washer, split-lock washer and hex nut (circled in **YELLOW**).

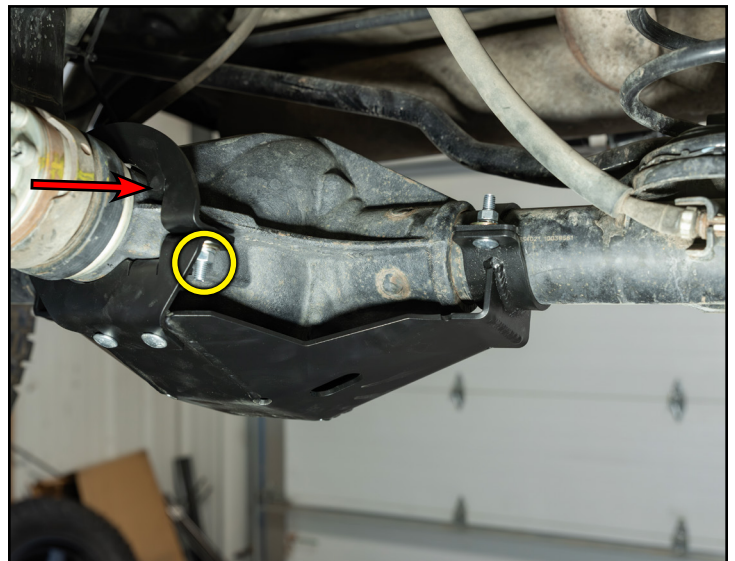

## Section 1: Installing the New Skid Plate

### Step #9

Center the axle with roughly 1/2" gap (**YELLOW** lines) between the cast material of the rear differential and the inside edge of the axle housing clamps on both sides of the housing, then push the entire assembly rearward to ensure clearance between the pinion clamps and the rear pinion.

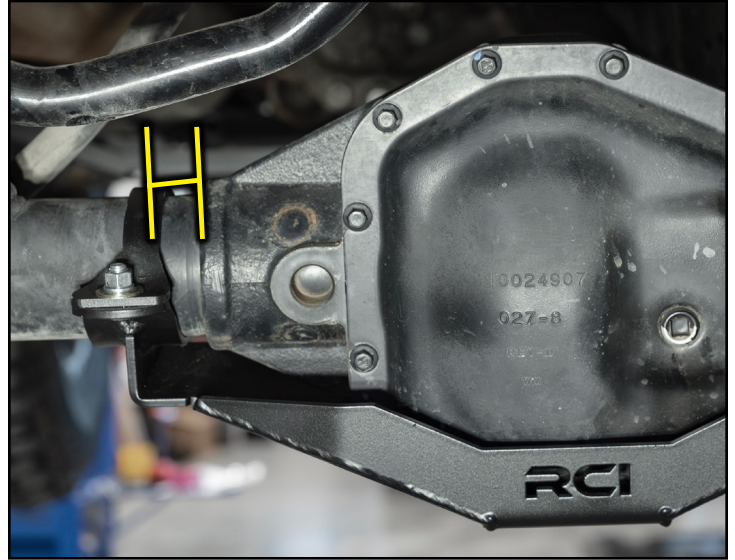

### Step #10 9/16" Wrench, 9/16" Socket & Ratchet

Once desired fitment has been achieved fully tighten the hardware in the sequence as shown.

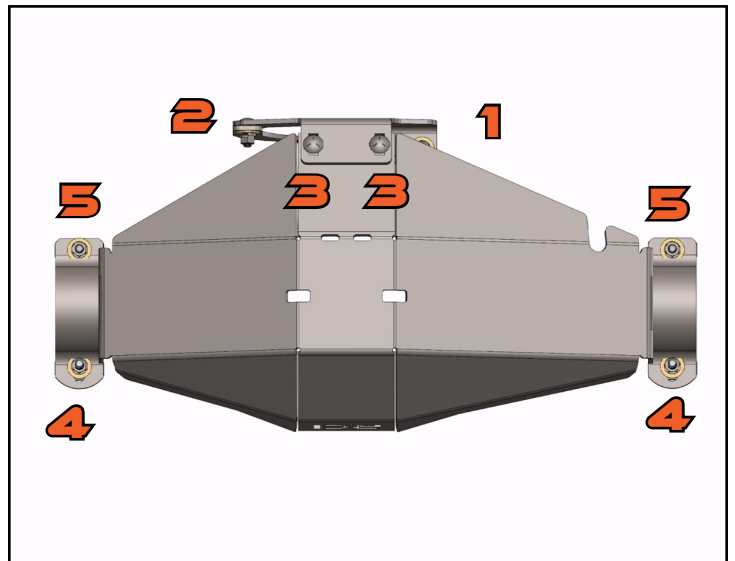

**CONGRATULATIONS, YOUR INSTALLATION IS COMPLETE!**

**ENJOY YOUR NEW RCI PROTECTION!**



**Share your new install with us on social media!  
We love seeing our products in the wild!**

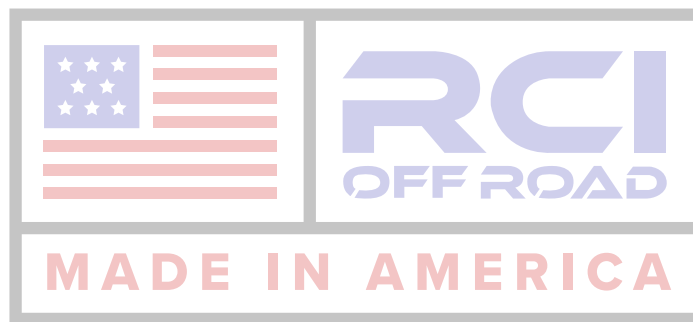

**Follow us on social media:**  
[instagram.com/rcioffroad/#](https://www.instagram.com/rcioffroad/)  
[facebook.com/RCIOffroad](https://www.facebook.com/RCIOffroad)  
[youtube.com/@RCIOFFROAD](https://www.youtube.com/@RCIOFFROAD)

**Contact:**  
1.970.797.3089  
[SALES@RCIOFFROAD.COM](mailto:SALES@RCIOFFROAD.COM)  
6701 N. FRANKLIN AVE. LOVELAND, CO 80538

**These instructions are provided as a courtesy by RCI Offroad**

Disclaimer: The products sold by RCI Metalworks are intended for off-road use only, should not be modified, and are for use only on the vehicle(s) specifically stated. RCI Metalworks makes no warranties express or implied, including of fitness for a particular purpose or merchantability. RCI Metalworks will not be liable for any damages arising out of the use or misuse of its products. It is the customers' responsibility to ensure the products are safely and properly attached to the vehicle, and all products should be installed by trained professionals. We strive to maintain extremely high-quality standards; however, all RCI Metalworks products are individually handcrafted, may vary slightly, and may contain minor imperfections. Due to the nature of raw aluminum, the material may have minor scratches and other blemishes caused by the manufacturing process, especially on the back side of product. RCI Metalworks is constantly seeking to improve its products and reserves the right to make changes to any product.