

24+ Landcruiser LC250 Transfer Case Skid Plate Install Guide

ITEM NO.	PART NUMBER	DESCRIPTION	QTY.
1	SM-00906	LC250 T-Case Skid	1
2	HW-00104	Mounting Plate #2	2
3	HW-00160	Mounting Plate #4	1
4	HW-00125	3/8 TRANSMISSION SPACER	2
5	HW-00023	5558B1M: M10-1.5 U-NUT .90MM-	1
6	HW-00162	M10 X 45 Flanged Bolt Partially Threaded	2
7	HW-00026	3/8 USS FLAT WASHER THRU HARD	3
8	HW-00025	M8-1.25 X 30MM HEX FLANGE BOLT	1
9	HW-00037	5/16 USS FLAT WASHER ZINC	1
10	HW-00088	M10-1.5 X 40MM NON SERRATED	1

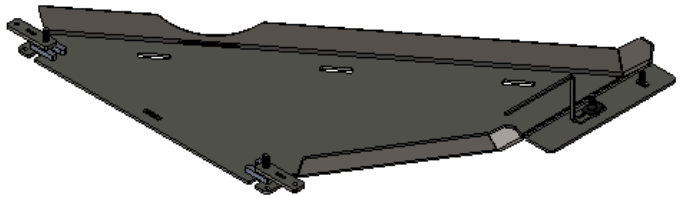

UNLESS OTHERWISE SPECIFIED:	PROPRIETARY AND CONFIDENTIAL	DRAWN	NAME	DATE
DIMENSIONS ARE IN INCHES TOLERANCES: FRACTIONAL: ±0.010 ANGULAR: BEND ±0.5 TWO PLACE DECIMAL ±0.015 THREE PLACE DECIMAL ±0.010	THE INFORMATION CONTAINED IN THIS DRAWING IS THE SOLE PROPERTY OF RCI Offroad. ANY REPRODUCTION IN PART OR AS A WHOLE WITHOUT THE WRITTEN PERMISSION OF RCI Offroad IS PROHIBITED.	NA	NA	NA
		Export Date		
RCI OFFROAD				
TITLE: Landcruiser LC250 T-Case Skid Install Guide BOM				
Item Number				REV
Default				1
DO NOT SCALE DRAWING		SCALE: 1:20	WEIGHT:	SHEET 1 OF 1

Figure 1: BOM

INSTALLATION STEPS:

****Use hand tools, impact wrenches may cause damage if over torqued.****

- 1) Begin by unpacking and removing all components and hardware. Please verify that all hardware and mounting components are present. Reference your original order invoice and verify all items are accounted for.
- 2) Pre-requisite steps for installation without an RCI 24+ Toyota Hybrid Transmission Skid Plate. If installing with a RCI 24+ Toyota Hybrid Transmission Skid Plate, skip this step.
 - a. Insert the MP2 Mounting Plates into the rear vehicle crossmember. Align the threaded holes of the MP2 with the large holes in the vehicle crossmember.
 - i. Insert the MP2 plates into the crossmember from the slotted cutouts in the crossmember.

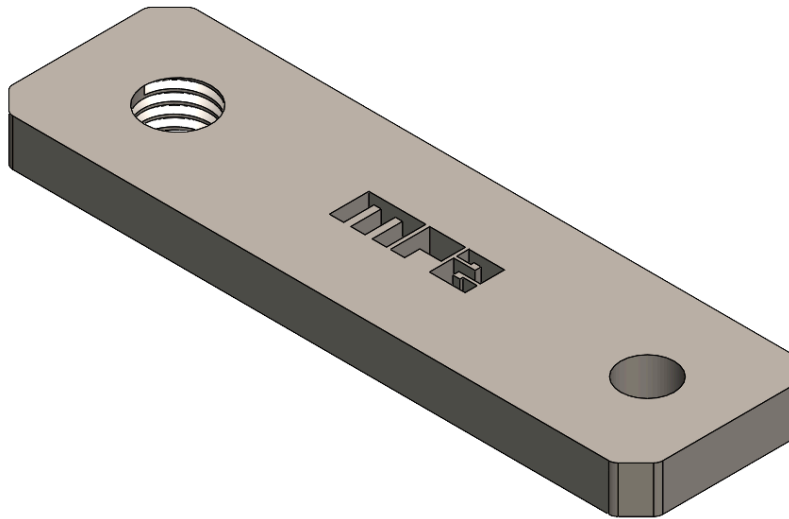



- ii. Align the threaded ends of the MP2s with the large holes in the rear crossmember.



- 3) Prepare front for installation.
 - a. If installing the RCI 24+ Landcruiser LC250 Transfer Case Skid Plate in conjunction with the RCI 24+ Toyota Hybrid Transmission Skid Plate, loosen the transmission skid plate mounting hardware so there is at least 1/4" gap between the rear of the transmission skid plate and the vehicle crossmember.
 - b. If installing the RCI 24+ Landcruiser LC250 Transfer Case Skid Plate without the RCI 24+ Toyota Hybrid Transmission Skid Plate, loosely install a set of M10 bolts with 3/8" washers in the MP2 plates in the crossmember.
 - c. Leave the bolts partially threaded for now.

- 4) Assemble the MP4 mounting plate by installing a M10 speedclip.

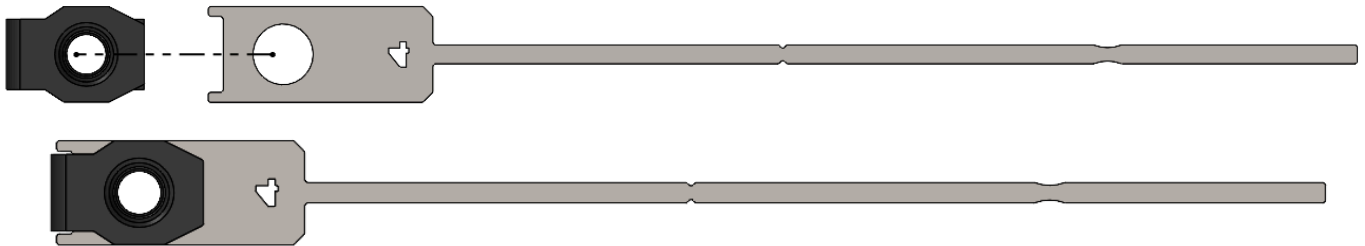

- 5) Bend the MP4 as depicted below.
 - a. Find the dimple nearest to the mounting hole and bend it up at a 90° angle

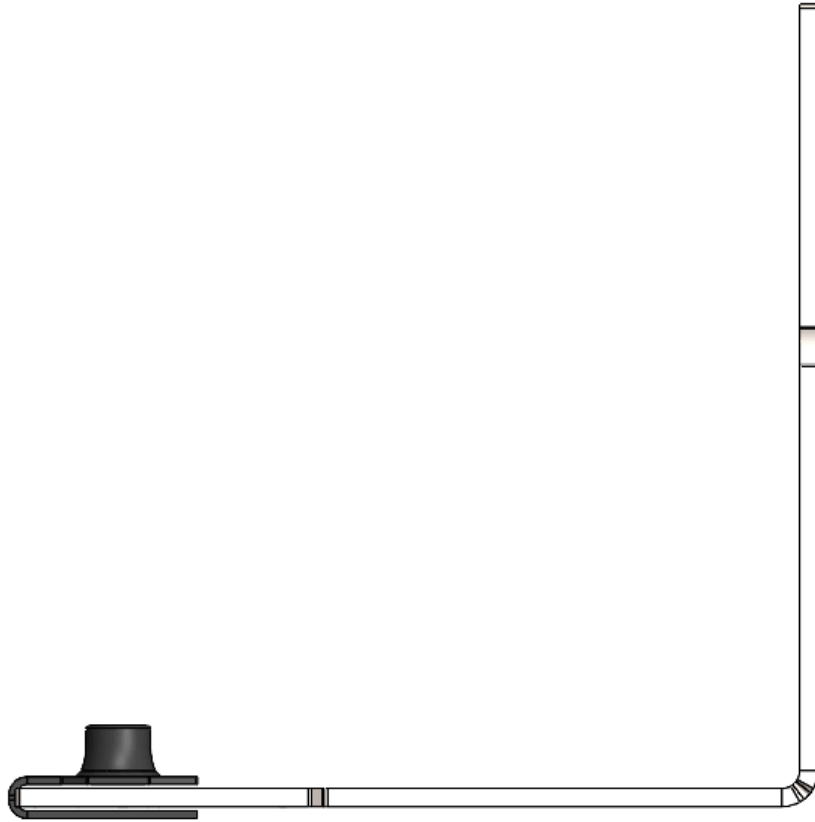

- 6) At the second dimple in the mounting plate bend it at a 90° angle to the left of the mounting hole as depicted below.



7) Remove the plastic tab located on the inside of the driver side frame.

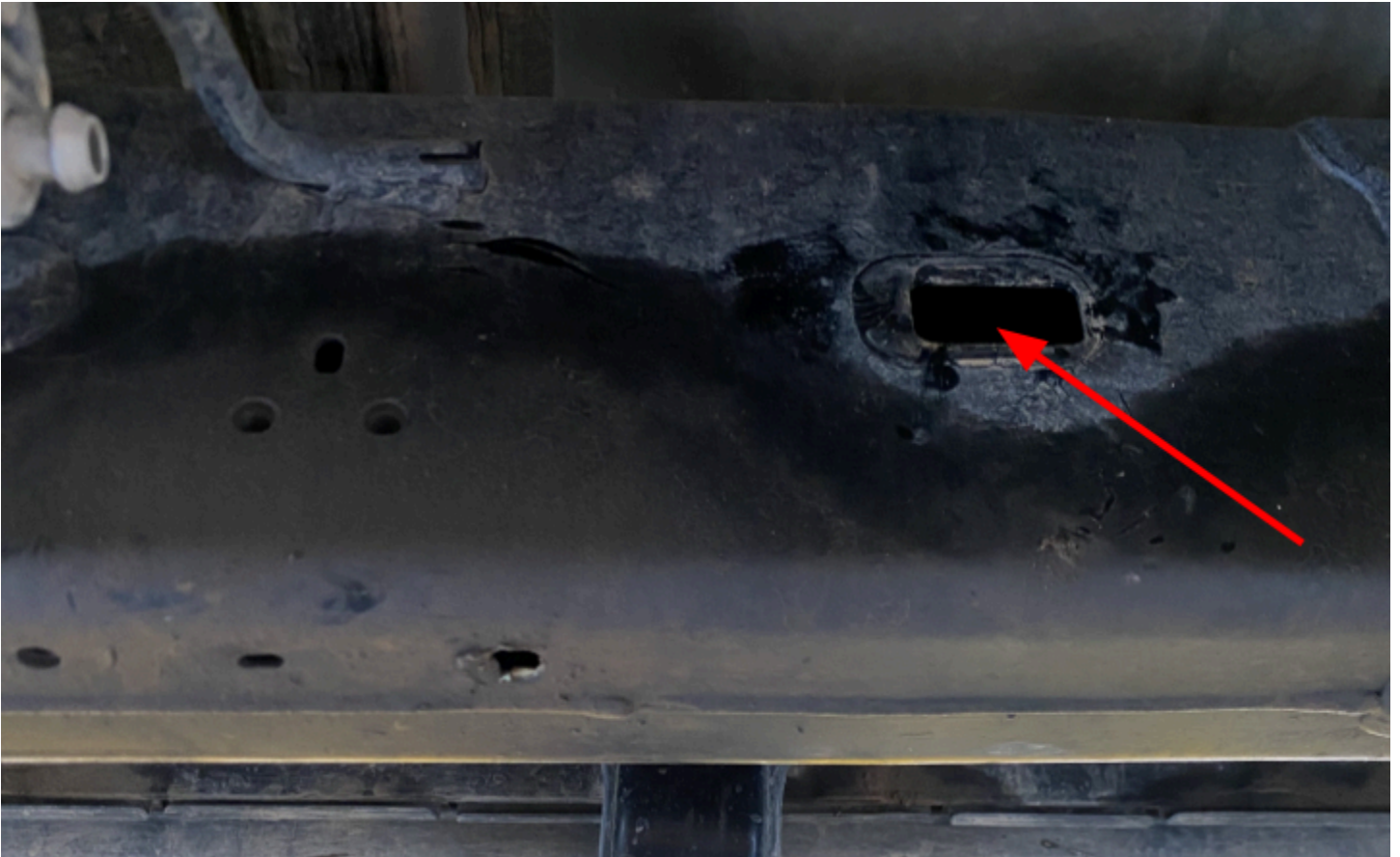

- 8) Insert the assembled MP4 into the slot in the frame and align the threads with the hole on the bottom of the frame.





- 9) Collect the RCI 24+ Landcruiser LC250 Transfer Case Skid Plate along with one (1) M10 x 40mm bolt, one (1) M8 x 30mm bolt, one (1) 3/8" washer, and one (1) 5/16" washer.
- 10) Slot the front of the skid plate into the front two partially installed M10 bolts and hinge the skid up until the outside holes align with the holes on the outer frame of the truck.



11) Use the M10 and M8 bolts to secure the back of the skid plate to the truck.



12) With the skid plate loosely installed, collect the two (2) 3/8" transmission spacers and install them between the skid plate and the crossmember as shown below.

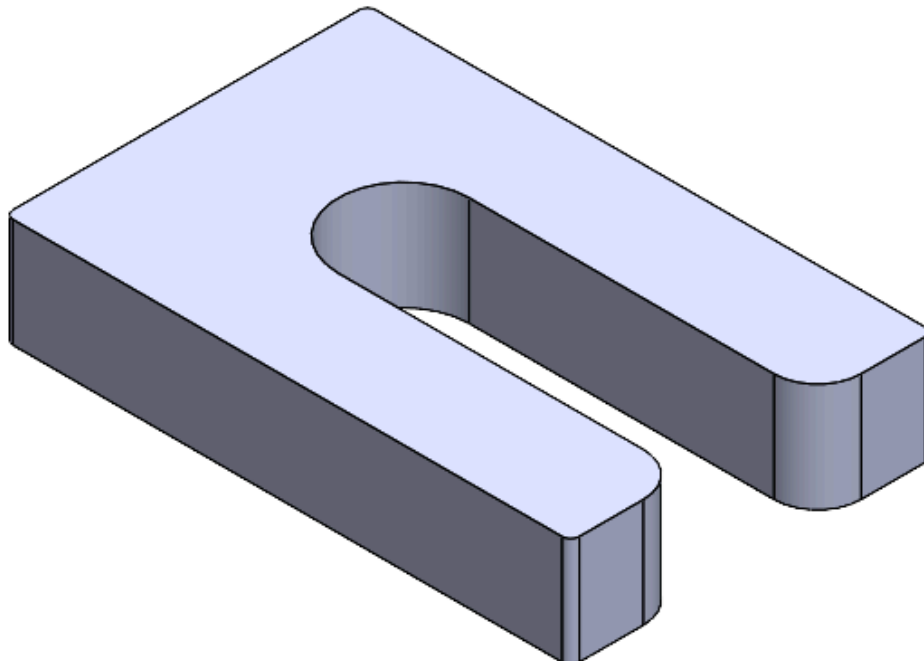



13) Align the skid plate and fully tighten all 4 mounting bolts.



Enjoy your new RCI protection!

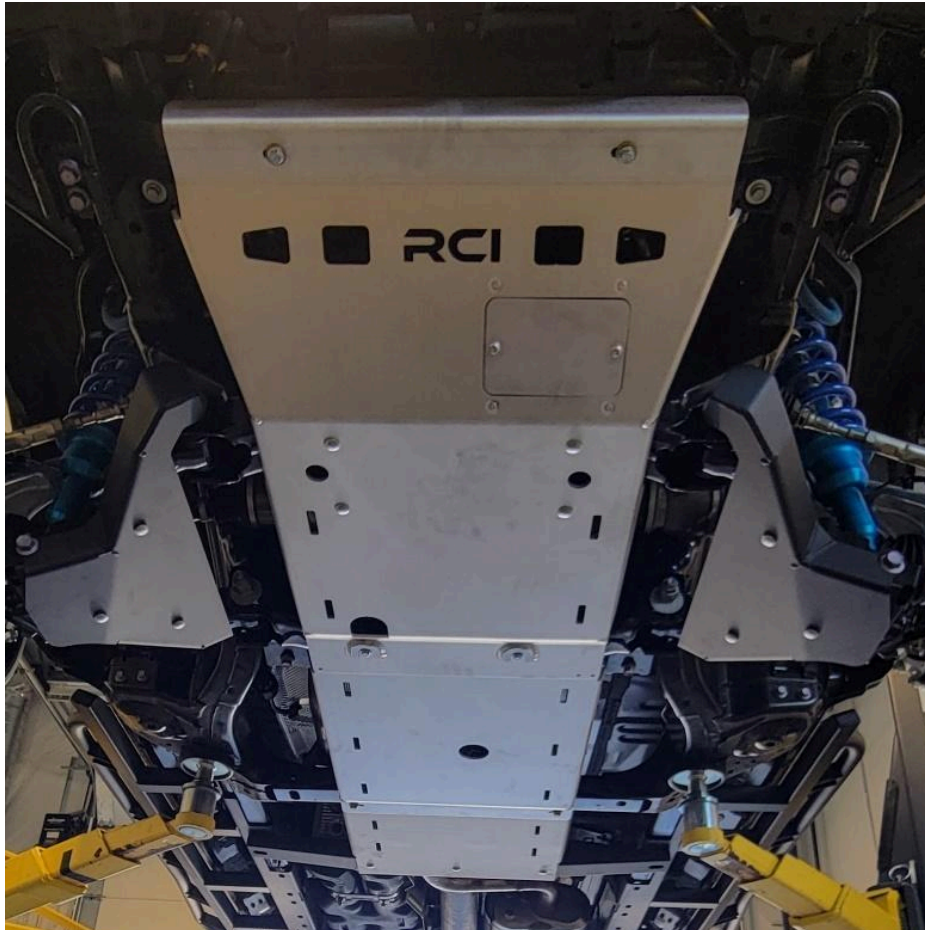

Share your new install with us on social media!

We love seeing our products out in the wild!

www.rcimetalworks.com

sales@rcioffroad.com

970-797-3089



Disclaimer: The products sold by RCI Metalworks are intended for off-road use only, should not be modified, and are for use only on the vehicle(s) specifically stated. RCI Metalworks makes no warranties express or implied, including of fitness for a particular purpose or merchantability. RCI Metalworks will not be liable for any damages arising out of the use or misuse of its products. It is the customers' responsibility to ensure the products are safely and properly attached to the vehicle, and all products should be installed by trained professionals. We strive to maintain extremely high quality standards; however, all RCI Metalworks products are individually handcrafted, may vary slightly, and may contain minor imperfections. Due to the nature of raw aluminum, the material may have minor scratches and other blemishes caused by the manufacturing process, especially on the back side of product. RCI Metalworks is constantly seeking to improve its products and reserves the right to make changes to any product.