

TIME FOR INSTALLATION

30 MINS. - 1 HOUR

RCI

EASY



METALWORKS

2020+ Ford Interceptor Engine Skid Plate Installation Guide

Contact RCI: SALES@RCIOFFROAD.COM
(970) 797-3089

Part Number	Description	Qty:
SM-01170	20+ Interceptor Engine Skid Plate	1
HK-00171	20+ Interceptor Engine Skid Plate HW Kit:	1
HW-00208	.5 x 188 Aluminum Unthreaded Spacer	2
HW-00023	M10-1.5 U-Nut .90mm	4
HW-00021	M10-1.5 x 35mm Hex Flange Bolt	4
HW-00013	3/8 Push On Bolt	2
HW-00187	M10 Bolt Protector	4
HW-00028	Full Moon Spacer	2

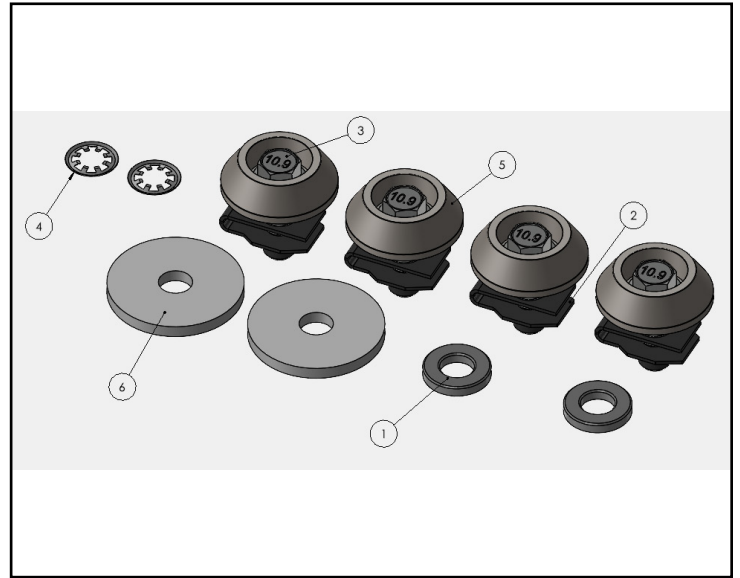
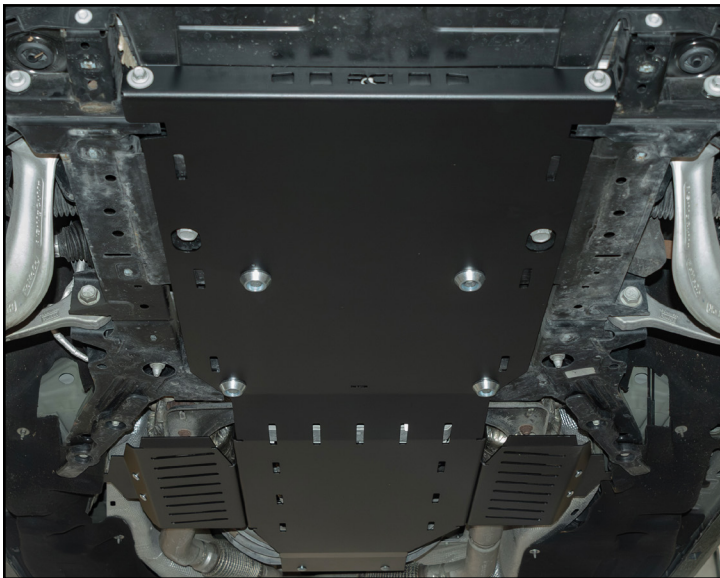
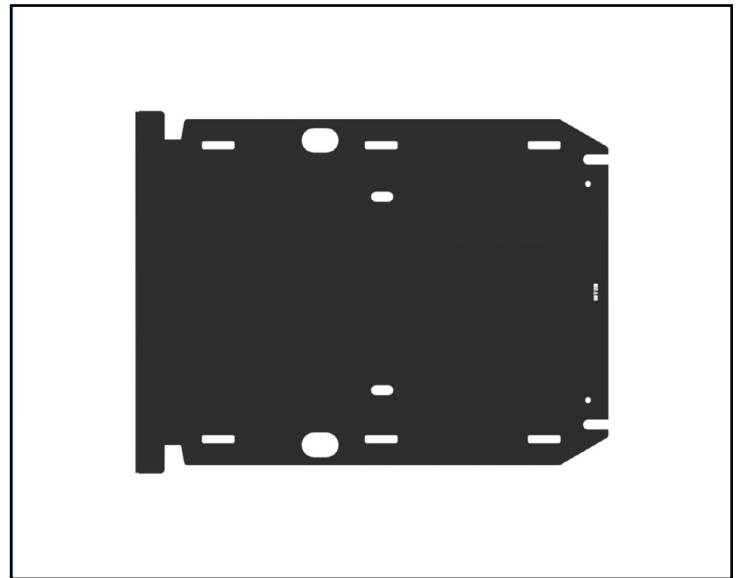

Caution: Use hand tools, impact wrenches may cause damage if over torqued.

Read the entire notes and instructions before installation.

Installation Notes

Installation Notes:

RH refers to the passenger side of the vehicle.

LH refers to the driver side of the vehicle.

Always use the proper torque specifications.

If applicable to this installation, torque specifications will be listed throughout the document.

Please read all of these instructions and familiarize yourself with the complete process **BEFORE** you begin.

General Safety:

Park your car in a safe, well lit, level area.

Shut the engine off and remove the key from the ignition switch.

Make sure any remote start devices are properly disabled.

ALWAYS wear safety glasses.

Make sure the parking brake is applied until the vehicle is safely lifted and supported.

Whether lifting a vehicle using an automotive lift or a hydraulic jack, utilize the factory specified lift points.

Lifting a vehicle in an incorrect location can cause damage to the suspension/running gear.

ALWAYS support the vehicle with properly rated jack stands.

ALWAYS read and follow all safety information and warnings for the equipment you are using.

Required Tools:

1/4", 3/8" & 1/2" Socket Sets & Ratchets

Floor Jack

Jack Stands

Combination Wrench Set

Plier Set

Torque Wrenches

Installation Overview:

Before installation, remove all components and hardware from their packaging and verify that all the components are present.

Section 1: Removing the Stock Components

Step #1 7mm Socket, Ratchet & Panel Clip Tool

Remove all components and hardware from their packaging, then verify that all the components are present.

If equipped: Remove the screws (circled in **RED**) and plastic clips (arrows) that secure the OEM splash shields to the vehicle.

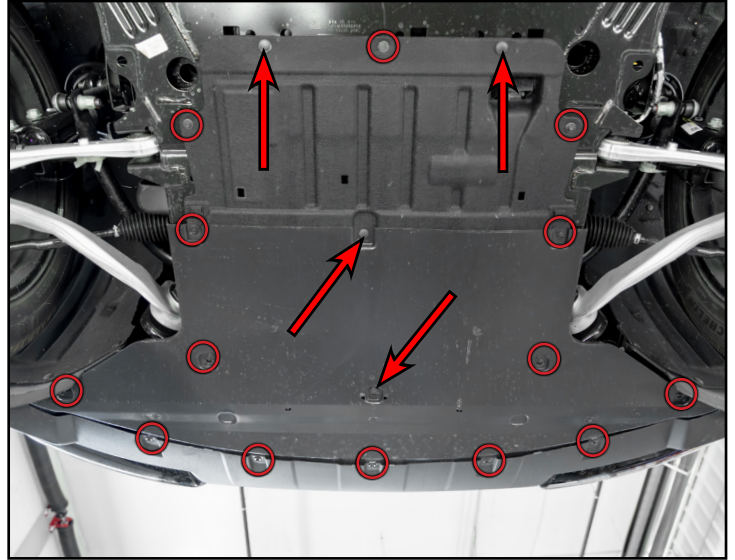

Step #2 13mm Socket & Ratchet

Remove the bolts (circled in **RED**) from the front of the sub-frame and set them aside.



Section 2: Installing the New Skid Plate

Step #1 15mm Socket & Ratchet

Install the provided M10 speed clips (highlighted in **GREEN**) into the mounting locations on the sub-frame as shown.

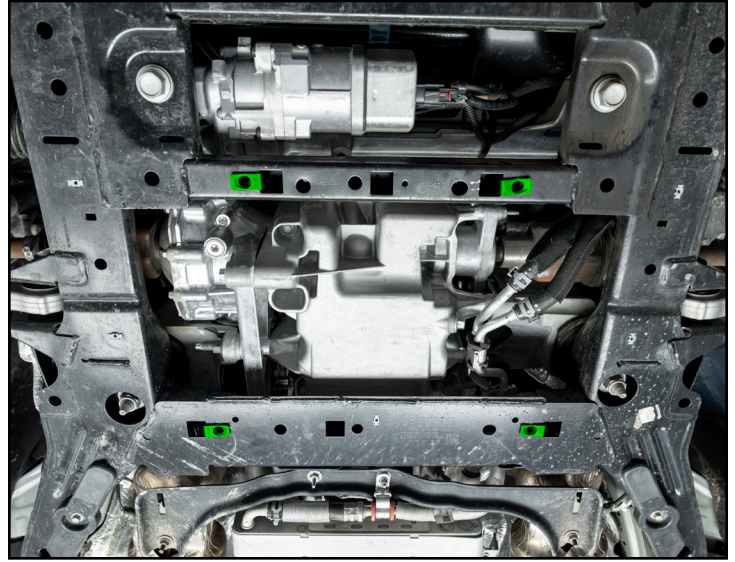

Step #2 15mm Socket & Ratchet

Assemble the provided M10 bolts by installing the provided bolt protectors onto them as shown.

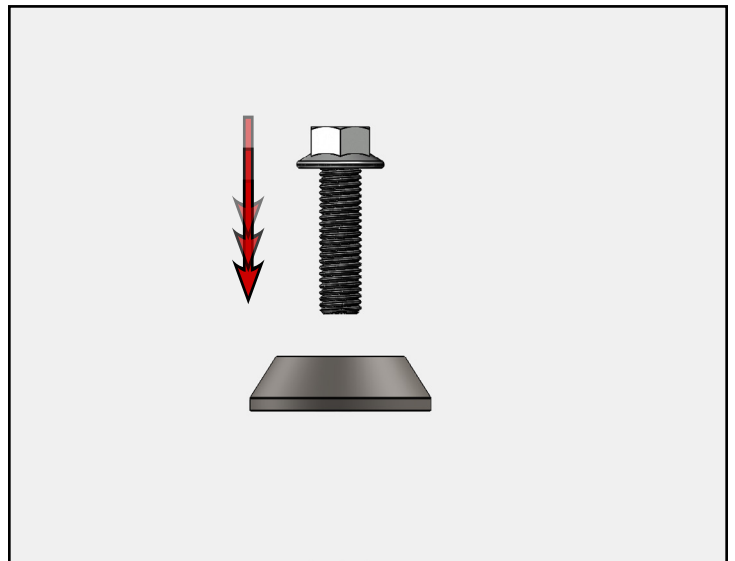

Section 2: Installing the New Skid Plate

Step #3 15mm Socket & Ratchet

Loosely install M10 bolts (arrows) into the rearmost speedclips previously installed in the front sub-frame.

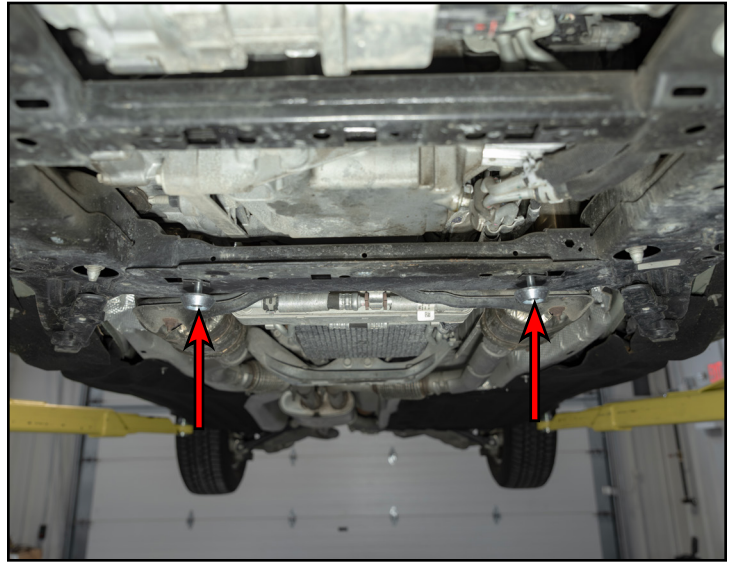

Step #4

Slide the M10 hardware (arrow) through the engine skid plate and install the provided full-moon spacers (highlighted in **GREEN**) onto the bolts.

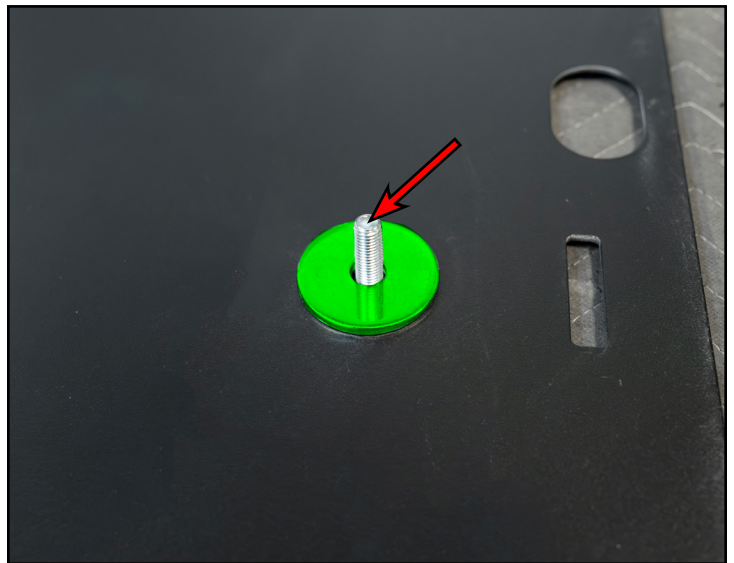

Section 2: Installing the New Skid Plate

Step #5

Install the provided retention washers (highlighted in **GREEN**) to secure the bolt protector, M10 bolt and spacer in place.

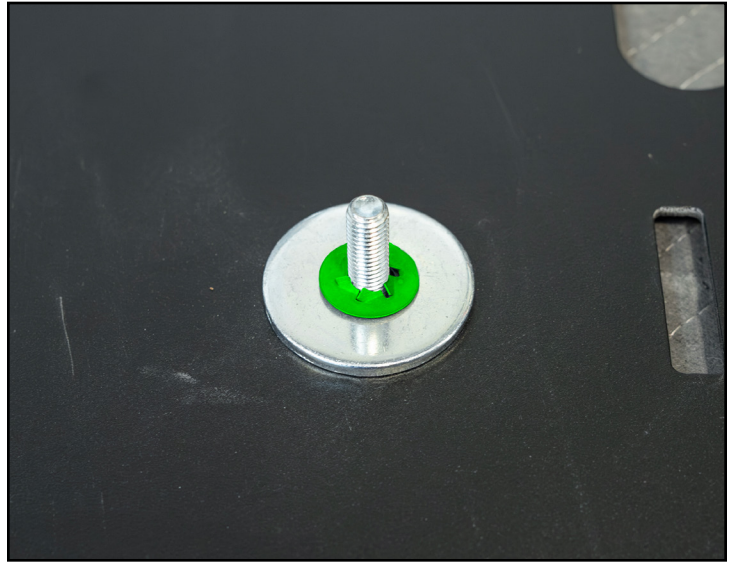

Step #6

Lift the engine skid plate and slide it onto the bolts that were previously installed at the rear of the front sub-frame.



Section 2: Installing the New Skid Plate

Step #7 15mm Socket & Ratchet

Loosely thread the assembled bolts (arrows) into the center mounting locations.

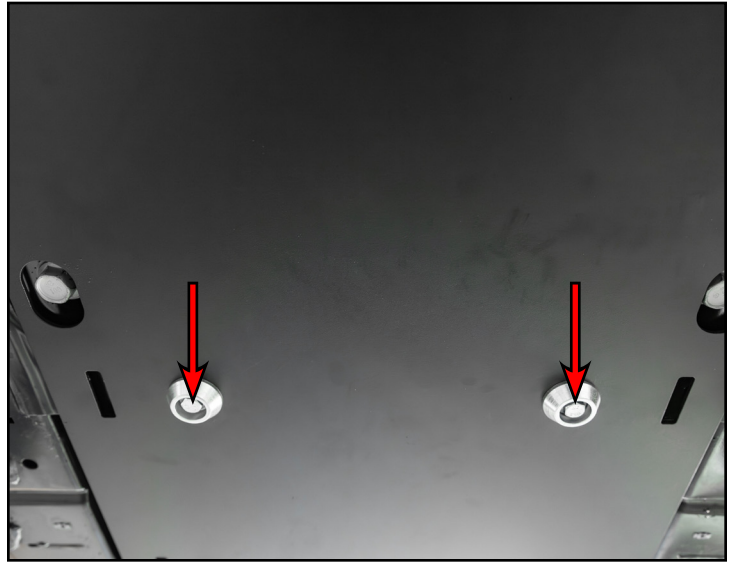

Step #8 13mm Socket & Ratchet

Reinstall the frontmost bolts through the engine skid plate and slide a provided spacer (highlighted in **GREEN**) onto the bolt.

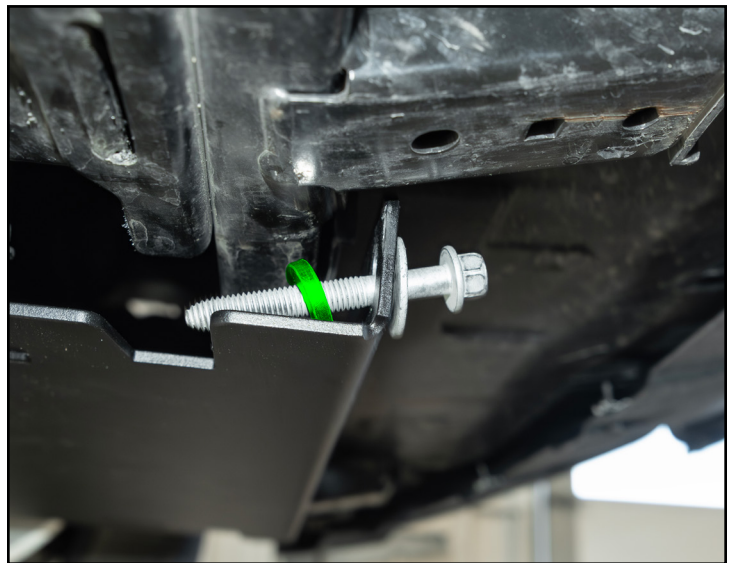

Section 2: Installing the New Skid Plate

Step #9 13mm Socket & Torque Wrench

Secure the front of the skid plate to the front sub-frame by threading the OEM bolts into their OEM mounting locations and torque the bolts (circled in **YELLOW**) to 46 Ft-lbs (63 Nm).



Step #10 15mm Socket & Ratchet.

Fully tighten the M10 bolts (circled in **YELLOW**) previously installed.

NOTE: If installing with an RCI Offroad Transmission Skid Plate, the transmission skid plate will need to be fully installed prior to tightening the M10 hardware.

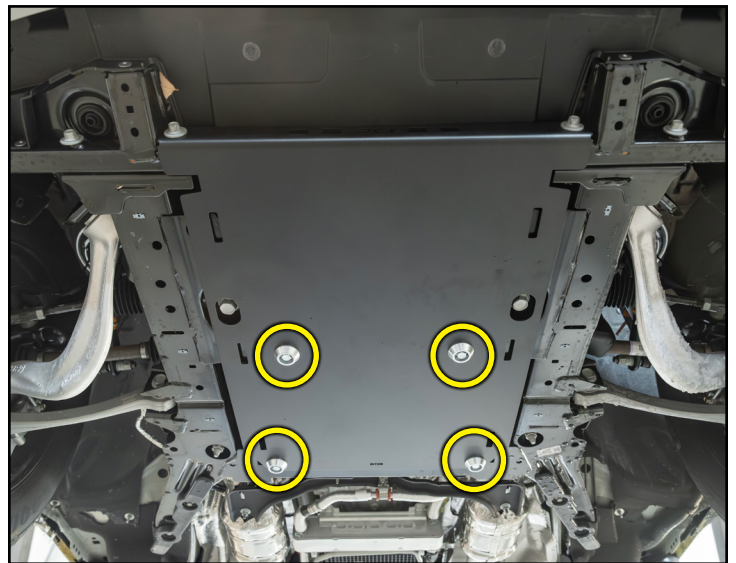

CONGRATULATIONS, YOUR INSTALLATION IS COMPLETE!

ENJOY YOUR NEW RCI PROTECTION!

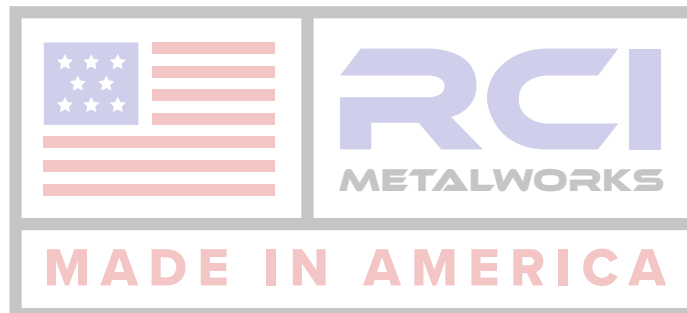
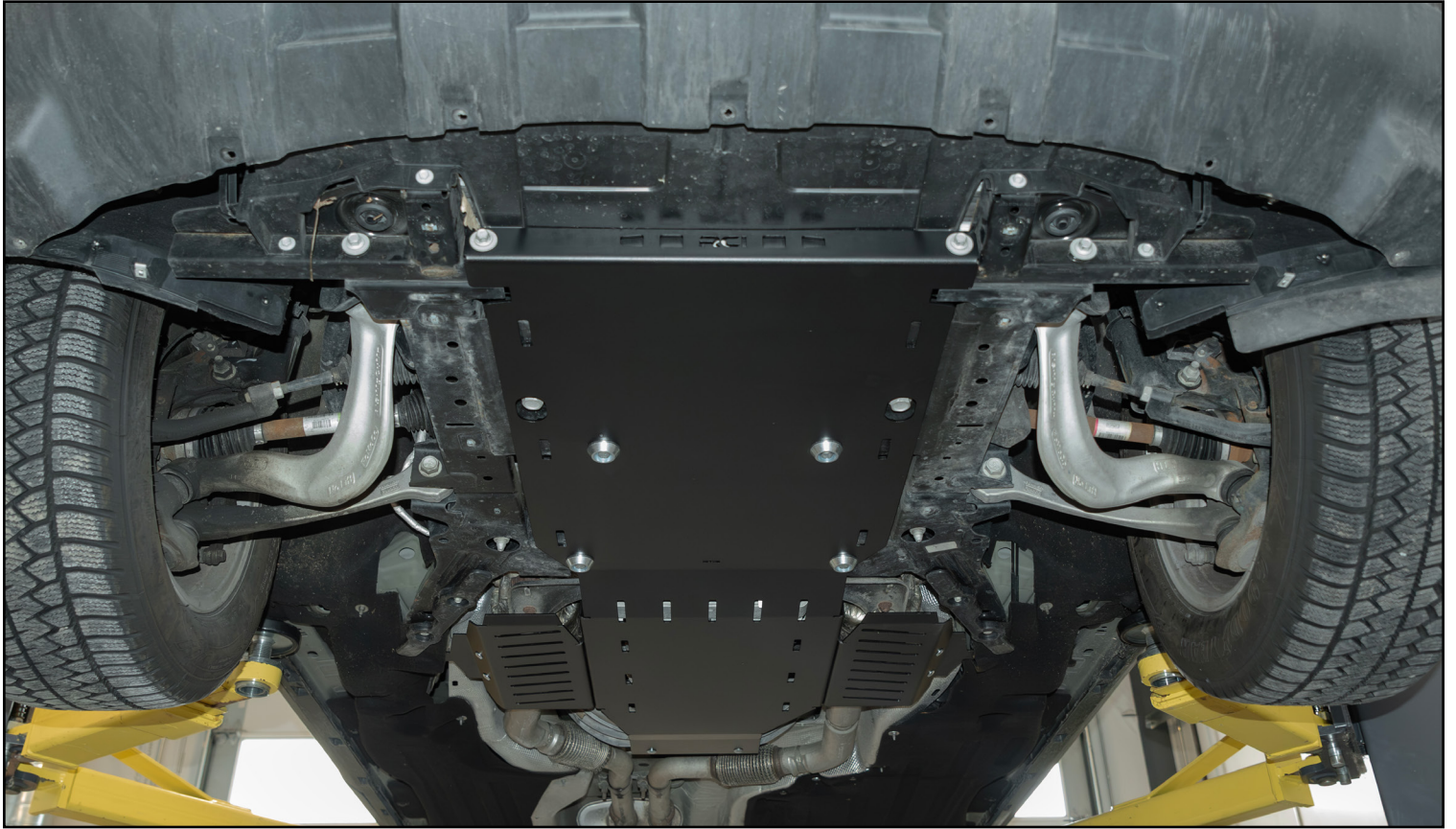

Contact:
1970.797.3089
SALES@RCIOFFROAD.COM
6701 N. FRANKLIN AVE. LOVELAND, CO
80538

These instructions are provided as a courtesy by RCI Metalworks

Disclaimer: The products sold by RCI Metalworks are intended for off-road use only, should not be modified, and are for use only on the vehicle(s) specifically stated. RCI Metalworks makes no warranties express or implied, including of fitness for a particular purpose or merchantability. RCI Metalworks will not be liable for any damages arising out of the use or misuse of its products. It is the customers' responsibility to ensure the products are safely and properly attached to the vehicle, and all products should be installed by trained professionals. We strive to maintain extremely high-quality standards; however, all RCI Metalworks products are individually handcrafted, may vary slightly, and may contain minor imperfections. Due to the nature of raw aluminum, the material may have minor scratches and other blemishes caused by the manufacturing process, especially on the back side of product. RCI Metalworks is constantly seeking to improve its products and reserves the right to make changes to any product.