

TIME FOR INSTALLATION

1-2 HOURS

RCI OFFROAD

ADVANCED



ADVANCED SKILLS
REQUIRED

25+ Toyota 4Runner Pike Front Bumper Installation Guide

Contact RCI: SALES@RCIOFFROAD.COM
(970) 797-3089

Part number	Description	Qty:
SM-01084	25+ T4R Pike Bumper	1
HK-00085	25+ T4R Pike Bumper Hardware Kit	1
HW-00022	1/2" USS Flat Washer Thru Hard	16
HW-00077	M10-1.25 x 30mm Hex Flange Bolt	8
HW-00130	M10 Nylock Nut	8
HW-00028	Full-Moon Washer	4

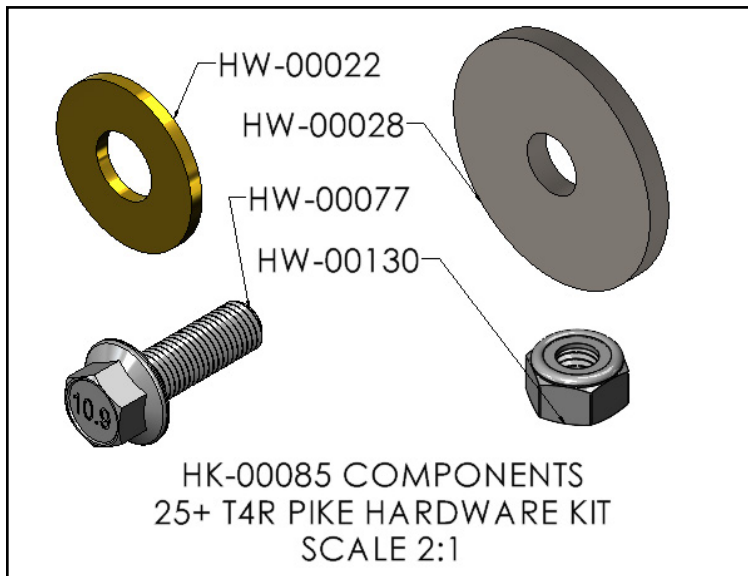

Caution: Use hand tools, impact wrenches may cause damage if over torqued.

Read the entire notes and instructions before installation.

DISCLAIMER:

The products sold by RCI Metalworks are intended for off-road use only, should not be modified, and are for use only on the vehicle(s) specifically stated. RCI Metalworks makes no warranties express or implied, including of fitness for a particular purpose or merchantability. RCI Metalworks will not be liable for any damages arising out of the use or misuse of its products. It is the customers' responsibility to ensure the products are safely and properly attached to the vehicle, and all products should be installed by trained professionals. We strive to maintain extremely high-quality standards; however, all RCI Metalworks products are individually handcrafted, may vary slightly, and may contain minor imperfections. Due to the nature of raw aluminum, the material may have minor scratches and other blemishes caused by the manufacturing process, especially on the back side of the product. RCI Metalworks is constantly seeking to improve its products and reserves the right to make changes to any product.

Installation of an RCI bumper requires removal of factory-installed components such as crash bars and foam impact absorbers. These components are designed for vehicle safety and impact absorption, and their removal may negatively impact occupant protection in a crash. RCI is not responsible for the removal of these components, and the owner/installer assumes all risks associated with their removal and any resulting consequences. It is the owner/installer's sole responsibility to understand the implications of removing these components before proceeding with installation. The installation of this RCI bumper, improper installation of this RCI bumper, and use or misuse of this RCI bumper with other components or failure to use it in conjunction with other components, could result in or cause serious personal injury, property damage or death.

RCI bumpers are not crash-tested and are intended for off-road use only. Vehicle owners are responsible for testing and recalibrating any affected sensors after bumper installation. While RCI may conduct preliminary sensor functionality checks during product development, this does not constitute testing to Original Equipment Manufacturer (OEM) specifications. RCI is not responsible and does not accept liability, for breakage or failure of parts as a result of rugged off-road use or reckless and/or improper installation. Modifications to your vehicle are done at your own risk and RCI does not accept liability or responsibility arising from damage caused by installing parts or doing modifications.

RCI performs off-road testing on its bumpers, including winch pulls, static and dynamic recovery pulls, and general off-road use. However, RCI is not liable for any damages arising from the use or misuse of its products. Customers are responsible for ensuring products are safely and properly attached to their vehicle, and professional installation is strongly recommended. After installing any off-road product, customers should test and recalibrate all safety sensors to ensure proper functionality. Do not rely on any safety sensor functionality until this verification is complete.

RCI Offroad bumpers with receiver hitches are not load rated. Using a receiver hitch for towing or other heavy-duty tasks is not recommended unless explicitly stated by the manufacturer. The bumper and receiver hitch are intended for off-road recovery use and not designed for sustained towing or load-bearing applications. Any misuse, such as towing or overloading, may result in bumper failure, vehicle damage, or personal injury. RCI is not responsible for any damages or injuries resulting from the use of the bumper with a receiver hitch beyond its intended purpose.

If an RCI product is purchased by a third party, such as a dealer, wholesaler, or installer, it is the third party's responsibility to inform the end customer of this disclaimer.

Installation Notes

Installation Notes:

RH refers to the passenger side of the vehicle.

LH refers to the driver side of the vehicle.

Always use the proper torque specifications.

If applicable to this installation, torque specifications will be listed throughout the document.

Please read all of these instructions and familiarize yourself with the complete process **BEFORE** you begin.

General Safety:

Park your car in a safe, well lit, level area.

Shut the engine off and remove the key from the ignition switch.

Make sure any remote start devices are properly disabled.

ALWAYS wear safety glasses.

Make sure the parking brake is applied until the vehicle is safely lifted and supported.

Whether lifting a vehicle using an automotive lift or a hydraulic jack, utilize the factory specified lift points.

Lifting a vehicle in an incorrect location can cause damage to the suspension/running gear.

ALWAYS support the vehicle with properly rated jack stands.

ALWAYS read and follow all safety information and warnings for the equipment you are using.

Required Tools:

1/4", 3/8" & 1/2" Socket Sets & Ratchets

Combination Wrench Set

Floor Jack

Jack Stands

Plier Set

Screwdriver set

Torque Wrenches

Trim Removal Tool

Angle Grinder –OR– Die Grinder

File

Section 1: Remove the Stock Front Bumper

Step #1

Remove all components and hardware from their packaging, then verify that all of the components and hardware are present.

NOTE: The installation of the RCI Pike Front Bumper requires the removal of the factory air dam prior to installation.



Step #2

Ensure your vehicle is parked on a smooth flat surface, then open the hood and support it properly.

Press down on the center of the plastic clips (arrows) that secure the cowl for the factory air box to the core support, then remove the cowl from the vehicle and set it aside.

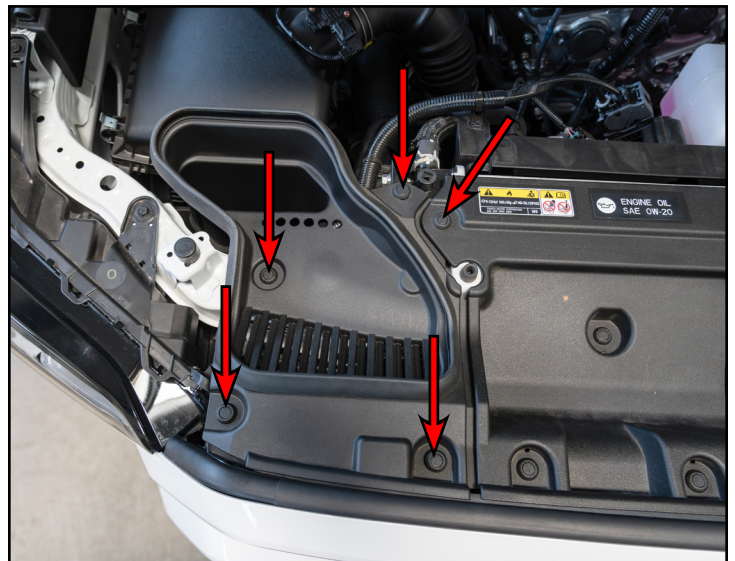

Section 1: Remove the Stock Front Bumper

Step #3

Press down on the center of the plastic clips (arrows) that secure the radiator cowl to the upper radiator core support, then remove it from the vehicle and set it aside.

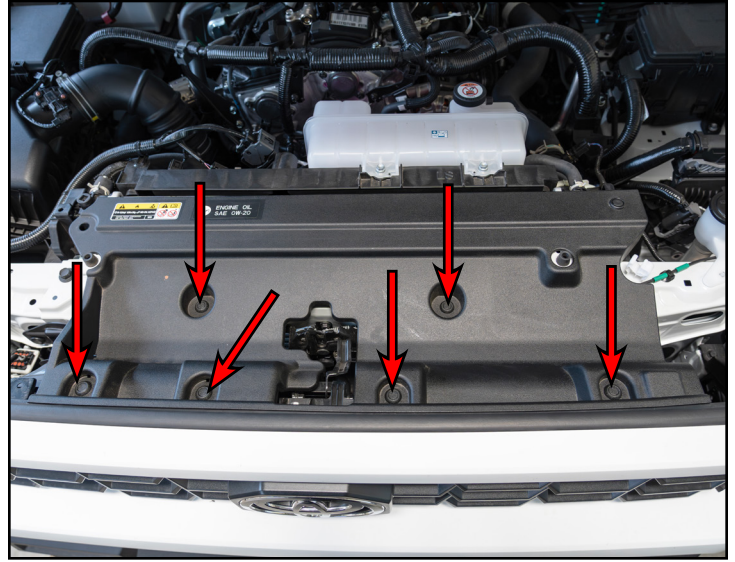

Step #4

Disconnect the two connectors (highlighted **RED** in inset photo) from the fog light and front bumper sensor harnesses on the RH side behind the headlight.

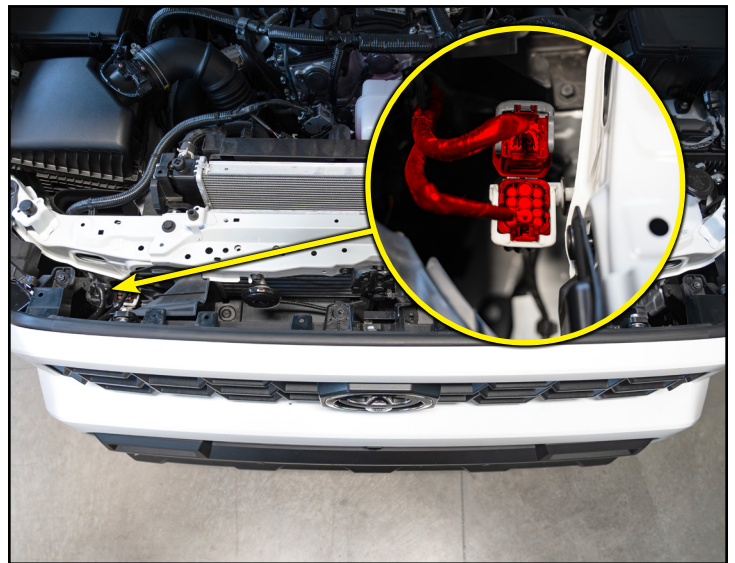

Section 1: Remove the Stock Front Bumper

Step #5 | 10mm Socket & Ratchet

Remove the screws (RED circles) and release the plastic clips (arrows) that secure the fender liners to the front bumper cover.

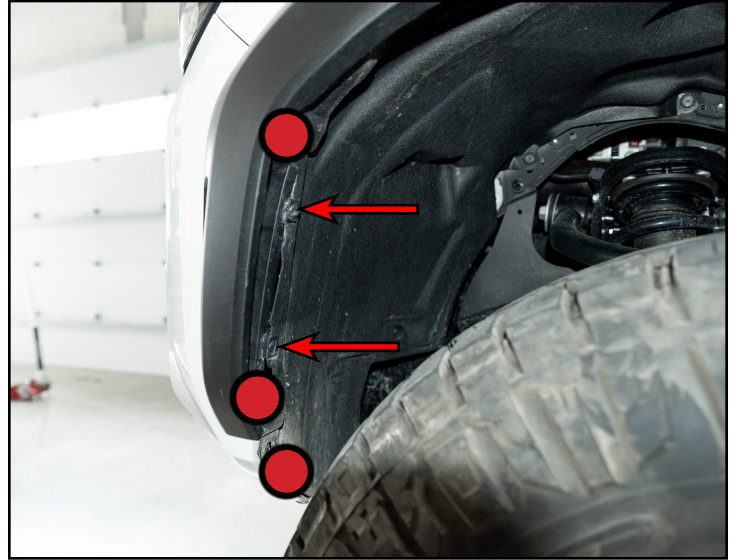

Step #6 | Trim Removal tool

Starting at the frontmost corner release the front portion of the fender flares by pulling outward to release the tabs from their mounting locations.

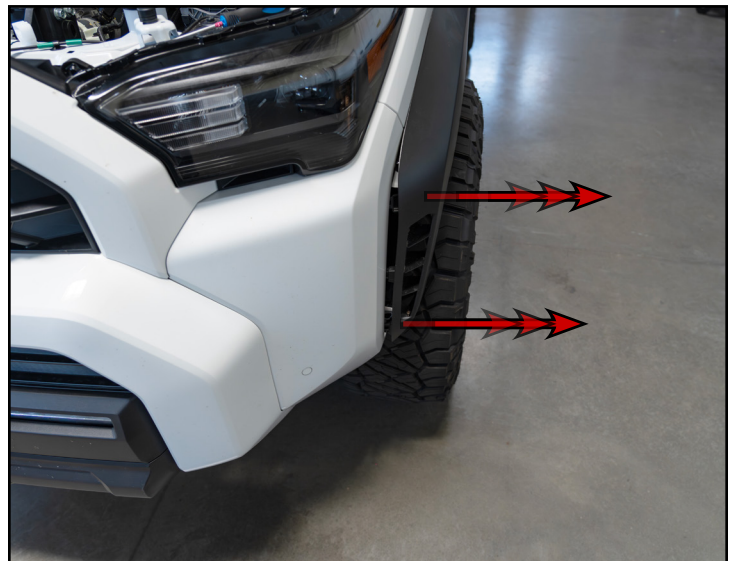

Section 1: Remove the Stock Front Bumper

Step #7	10mm Socket & Ratchet
----------------	----------------------------------

Remove the screw (arrow) that is under the front fender flare.

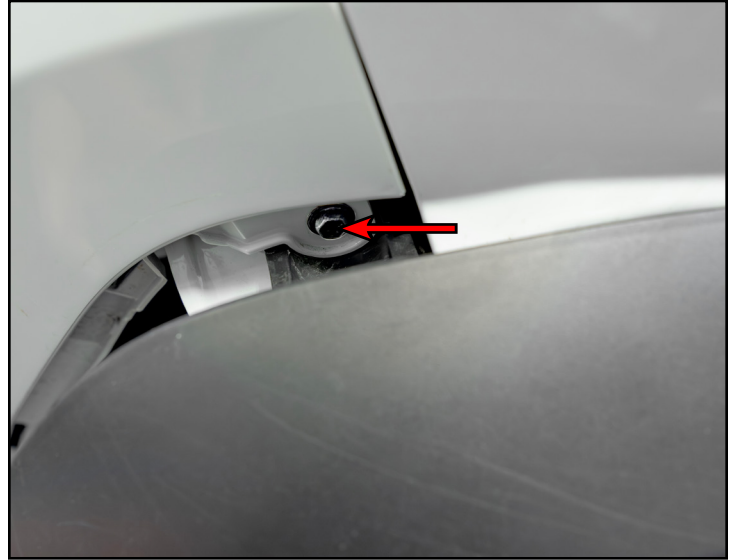

Step #8	
----------------	--

Starting from the outside corners of the front bumper cover, release the tabs from their mounting locations by pulling outward.



Section 1: Remove the Stock Front Bumper

Step #9 | 10mm Socket & Ratchet

Remove the two bottom bolts that secure the lower front bumper cover tabs to the lower radiator core support.



Step #10 | 10mm Socket & Ratchet

Remove the bolts (arrows) that secure the front bumper to the upper core support, then remove the front bumper cover from the vehicle and set it aside.

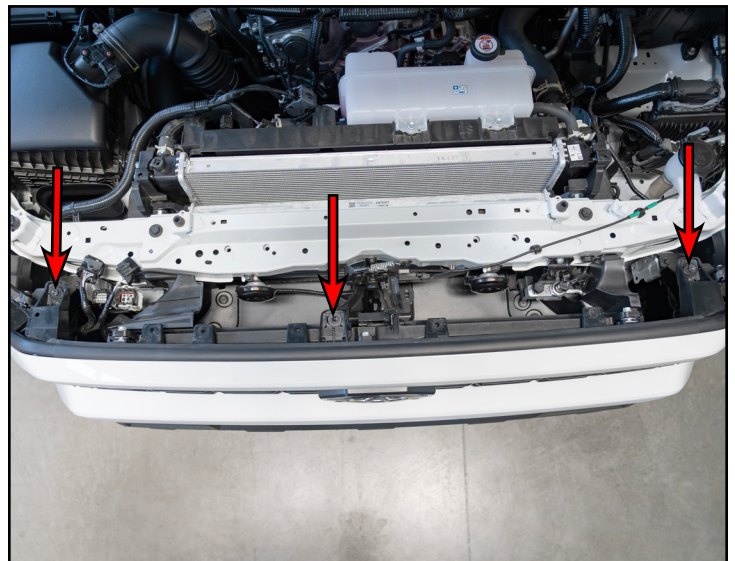

Section 1: Remove the Stock Front Bumper

Step #11 | 17mm Socket & Ratchet

Remove the bolts (arrows) that secure the front bumper reinforcement brace, repeat for the opposite side and remove the front bumper reinforcement brace from the vehicle.

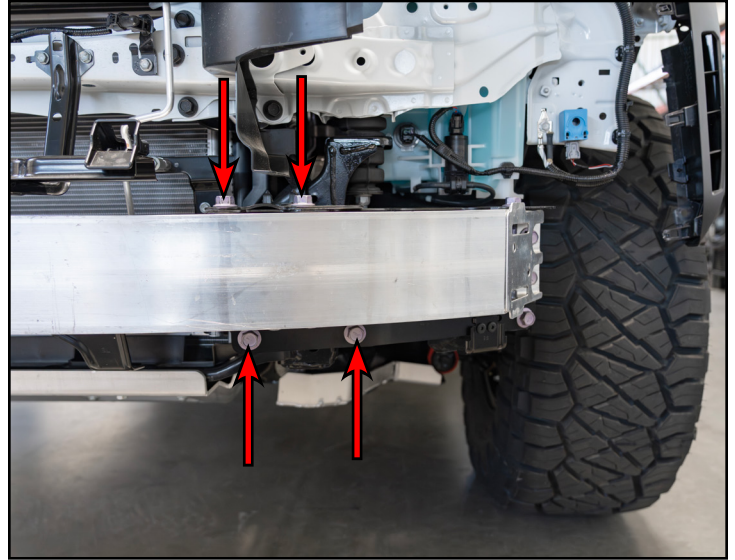

Step #12 | Phillips Head Screwdriver

Remove the screws (arrows) that secure the lower front bumper cover panel to the front bumper cover.

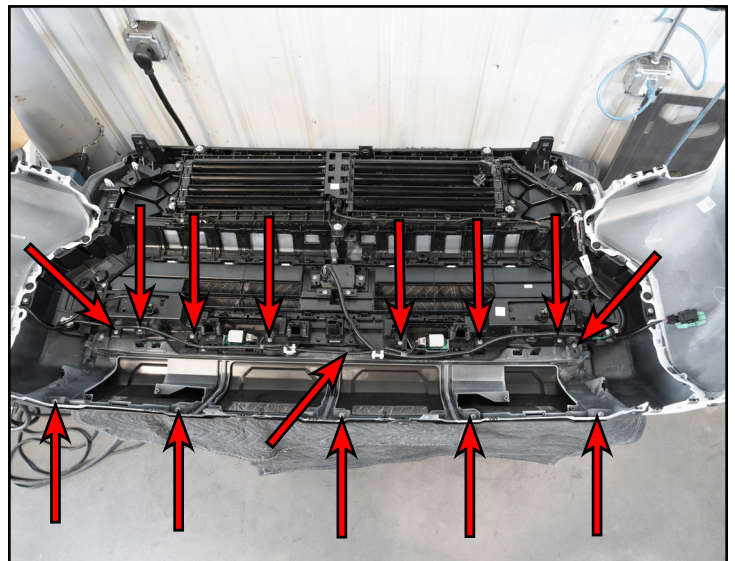

Section 1: Remove the Stock Front Bumper

Step #13 | Trim Removal Tool

Release the tabs (highlighted in **RED**) that secure the lower front bumper cover panel to the grille.

Release the clips (arrows) that secure the wiring harness to the grille, then move the harness to ensure it is out of the way during the cutting process.

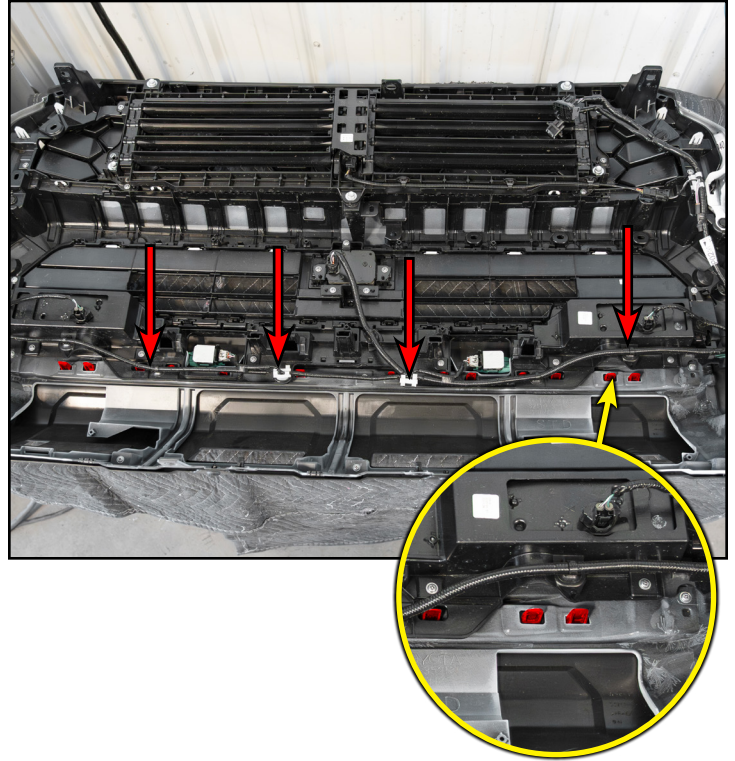

Step #14 | Trim removal Tool

Remove the clips (arrows) that secure the plastic cover to the front bumper cover, then remove the plastic cover panel from the front bumper cover.

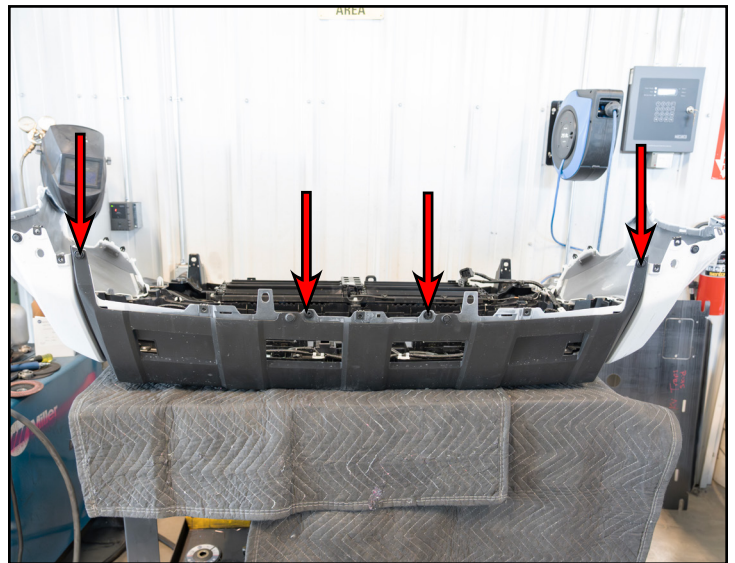

Section 2: Installing the New RCI Front Bumper

Step #15 | Angle Grinder –OR– Die Grinder

Mask off the area around where the cuts will be made to protect the remainder of the front bumper cover.

Cut the lower portion of the front bumper cover (highlighted in **RED**), ensuring that the cut takes place at least an 1/8" from the edge, then discard the lower section.

CAUTION: Be careful when cutting the lower portion of the front bumper cover to not cut through the wiring harness clip locations.



Step #16 | File –OR– Sander

Clean and deburr the edges where the front bumper cover was cut.



Section 2: Installing the New RCI Front Bumper

Step #1 | Phillips Head Screwdriver

Reinstall the clips (circled in **YELLOW**) into place to secure the wiring harness (highlighted in **GREEN**) in place.

Reinstall the screws (arrows) to secure the remaining front bumper cover to the grille.

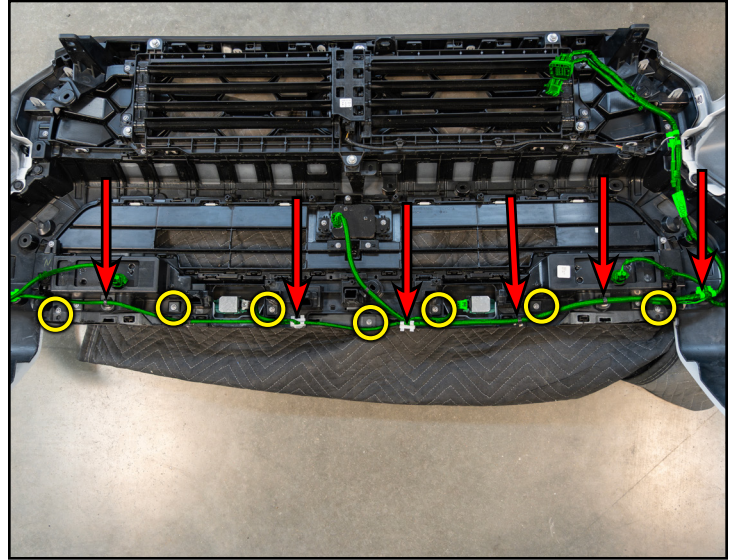

Step #2

Install the full moon washer (highlighted in **GREEN**) onto the existing stud on the bumper reinforcement bracket as shown.

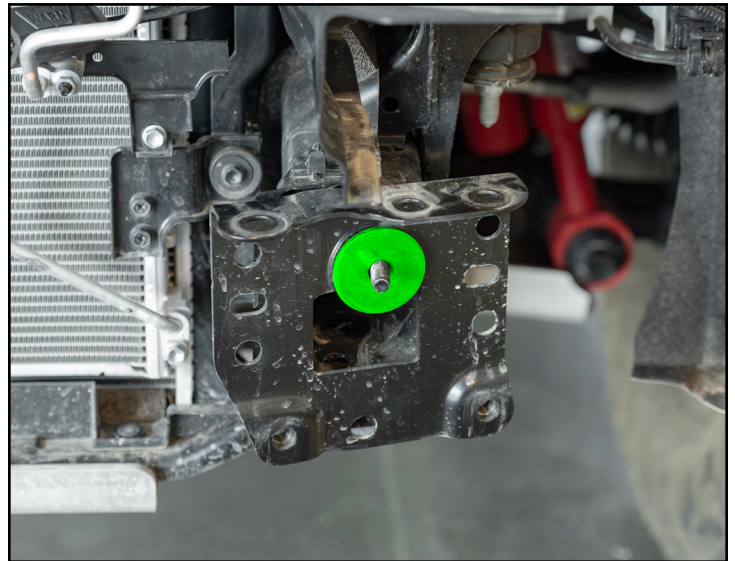

Section 2: Installing the New RCI Front Bumper

Step #3

For RCI Pike installations that will utilize any front bumper mounted accessories; install the accessories into their mounting locations and secure them in place at this time.



Step #4 17mm Socket & Ratchet

Lift the new RCI bumper up into place and loosely reinstall the M12 bolts (arrows in inset photo) to secure the new RCI Pike front bumper in place.

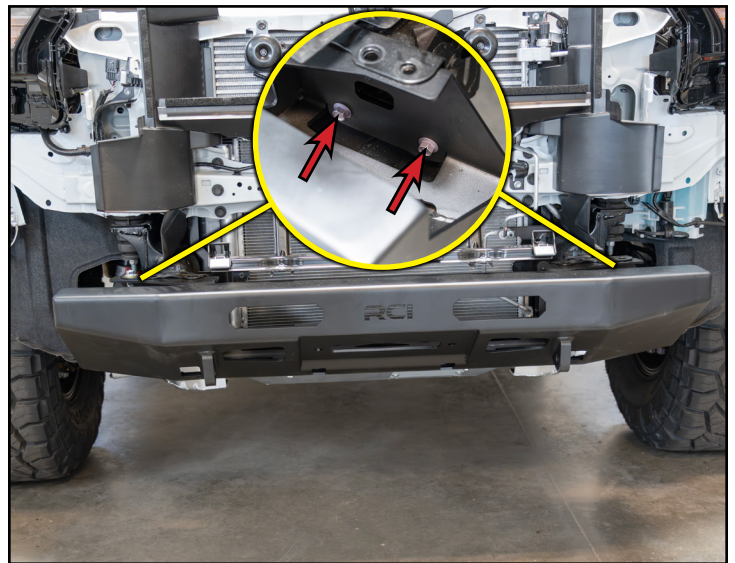

Section 2: Installing the New RCI Front Bumper

Step #5 | 17mm Wrench, 14mm Socket & Ratchet

Slide the provided M10 bolt (arrow) through the RCI Pike bumper, then align a provided full moon washer (highlighted in **GREEN**) in between the new bumper and the stock bumper brackets and secure the bolt with a provided washer and nylock nut.

Ensure all of the mounting hardware is loosely installed to allow adjustments.

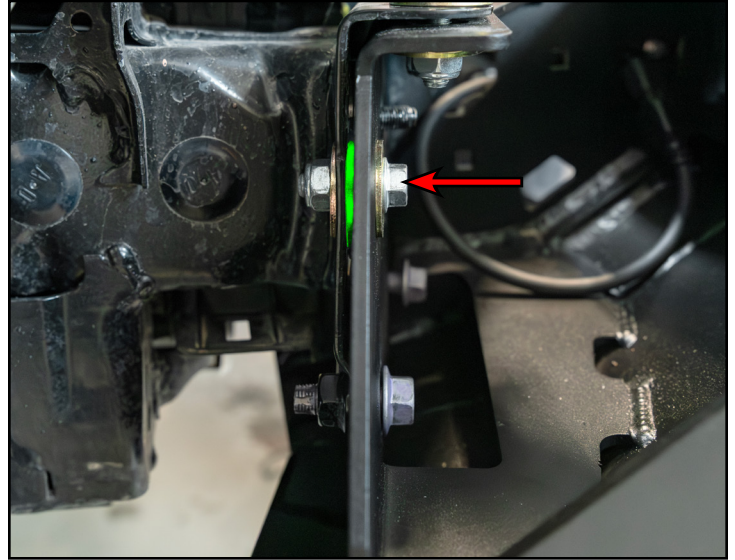

Step #6 | 17mm Wrench, 14mm Socket & Ratchet

Loosely install the provided M10 hardware (arrows) into the upper mounting locations.

Using a floor jack lift the bumper and ensure the alignment is level on both sides of the front bumper.

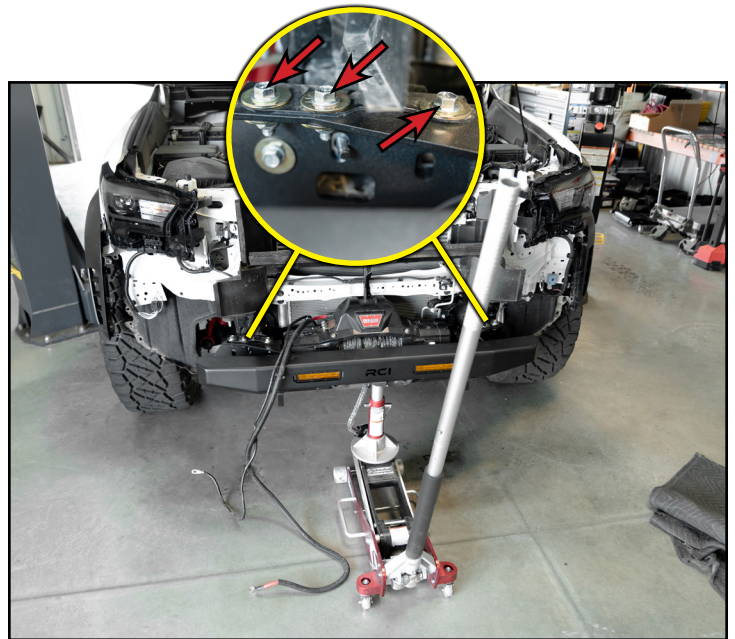

Section 2: Installing the New RCI Front Bumper

Step #7 14mm Wrench, 17mm Socket & Ratchet

Once desired fitment has been achieved, fully tighten the center M10 hardware (circled in **YELLOW**), then fully tighten the upper M10 hardware (arrows).

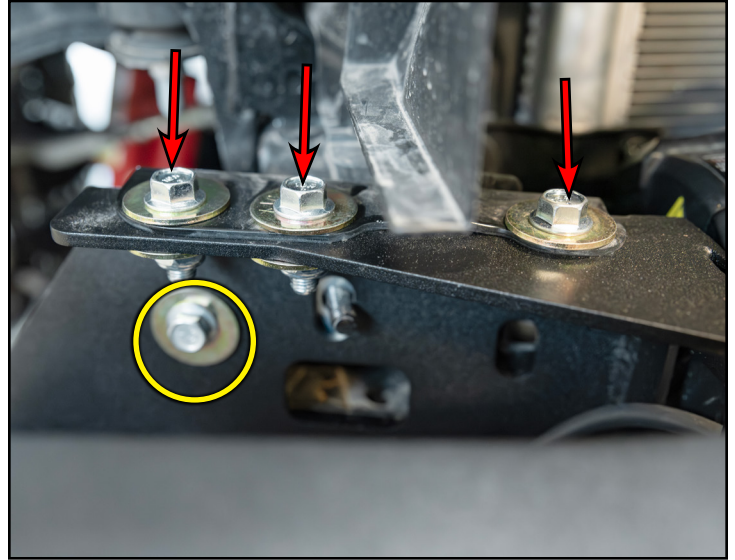

Step #8 17mm Socket & Torque Wrench

Torque the factory bolts (circled in **YELLOW**) to 75 Ft-lbs (101 Nm).



Section 2: Installing the New RCI Front Bumper

Step #9

Route any winch or front bumper accessories wiring that may have been installed.



Step #10 10mm Socket & Ratchet

Reinstall the remaining front bumper cover in the reverse order of removal.



Section 2: Installing the New RCI Front Bumper

Step #11

Reconnect the wiring harness (highlighted in **GREEN**) to the connectors.

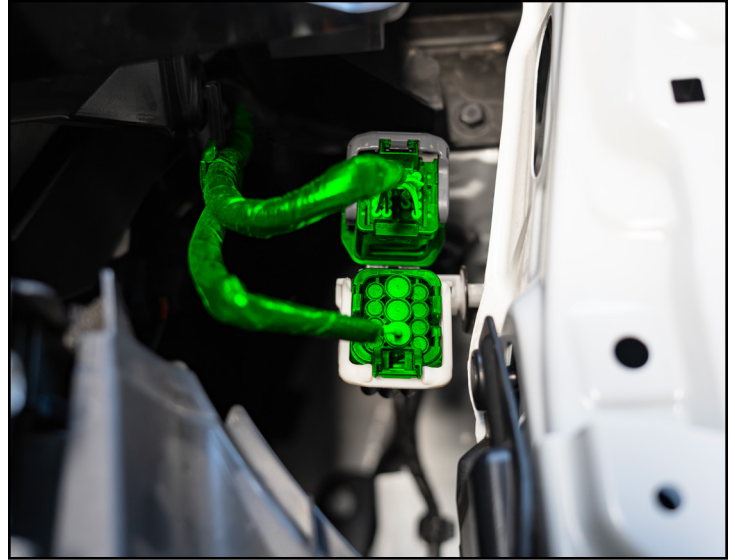

Step #12

Reinstall the plastic cowls and secure them by reinstalling the plastic clips (arrows).

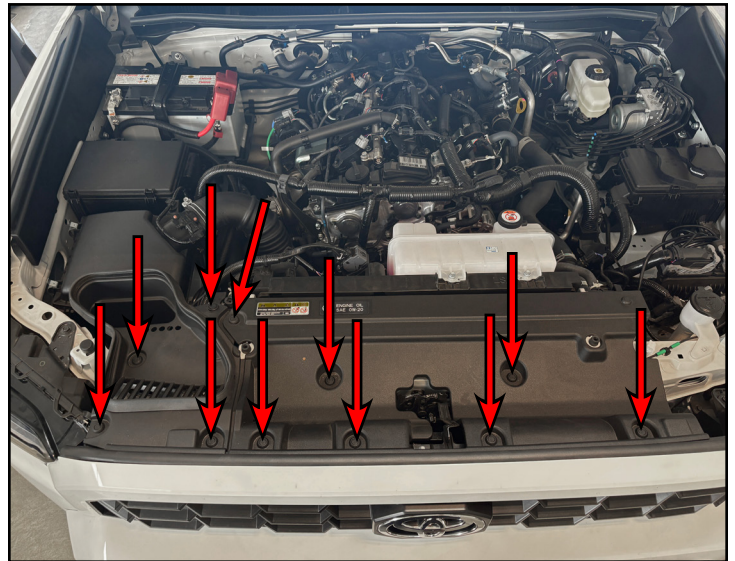

CONGRATULATIONS, YOUR INSTALLATION IS COMPLETE!

ENJOY YOUR NEW RCI PROTECTION!



**Share your new install with us on social media!
We love seeing our products in the wild!**

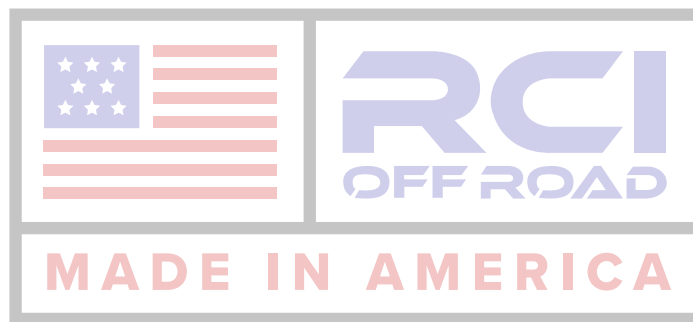

Follow us on social media:
[instagram.com/rcioffroad/#](https://www.instagram.com/rcioffroad/)
[facebook.com/RCIOffroad](https://www.facebook.com/RCIOffroad)
[youtube.com/@RCIOFFROAD](https://www.youtube.com/@RCIOFFROAD)

Contact:
1.970.797.3089
SALES@RCIOFFROAD.COM
6701 N. FRANKLIN AVE. LOVELAND, CO 80538

These instructions are provided as a courtesy by RCI Offroad

Disclaimer: The products sold by RCI Metalworks are intended for off-road use only, should not be modified, and are for use only on the vehicle(s) specifically stated. RCI Metalworks makes no warranties express or implied, including of fitness for a particular purpose or merchantability. RCI Metalworks will not be liable for any damages arising out of the use or misuse of its products. It is the customers' responsibility to ensure the products are safely and properly attached to the vehicle, and all products should be installed by trained professionals. We strive to maintain extremely high-quality standards; however, all RCI Metalworks products are individually handcrafted, may vary slightly, and may contain minor imperfections. Due to the nature of raw aluminum, the material may have minor scratches and other blemishes caused by the manufacturing process, especially on the back side of product. RCI Metalworks is constantly seeking to improve its products and reserves the right to make changes to any product.