

RCI Lexus GX460 Roof Rack Installation Guide

ITEM NO.	PART NUMBER	DESCRIPTION	QTY.
1	SM-00847 (Passenger)	GX460 Roof Rack Side Panel Passenger	1
2	SM-00846 (Driver)	GX460 Roof Rack Side Panel Driver	1
3	SM-00360	REAR Fairing	1
4	SM-00848	GX460 Roof Rack Front Faring	1
5	SM-00849	Roof Rack Foot UNI1	2
6	SM-00850	Roof Rack Foot UNI2	4
7	HW-00041	Roof Rack Extrusion Cross Bar	8
8	HW-00017	1/4-20 X 7/8 BUTTON SOC CAP BLACK	40
9	HW-00019	1/4 SAE FLAT WASHER BLK ZINC	40
10	HW-00031	1/4-20 KEPS NUT 18-8 S.S. BLACK	8
11	HW-00038	5/16-18 X 1 CARRIAGE BOLT BLACK GR-5	12
12	HW-00119	5/16 USS FLAT WASHER BLK ZNC	12
13	HW-00176	5/16-18 NYLON INSERT LOCK NUT BLK	12
14	HW-00145	M8 x 1.25 x 50mm Flanged Bolt Partial Thread	12
15	HW-00175	M8 x 1.125 Bonded Washer	24
16	HW-00121	1 X 4-1/2 RUBBER BUMPER W/ 2	6
17	HW-00103	Front Fairing Weather Stripping	1



RCI OFFROAD			
TITLE:			
Lexus GX460 Roofrack Install Guide			
Item Number	SKU	REV	
BOM	FG-00491	1	
DO NOT SCALE DRAWING		SCALE: 1:50 WEIGHT:	SHEET 1 OF 2

Figure 1:BOM

INSTALLATION STEPS:

****Use hand tools, impact wrenches may cause damage if over torqued.**

1. Begin by unpacking and removing all components and hardware. Please verify that all hardware, components, and mounting components are present. Please reference your original order invoice and verify all items are accounted for.

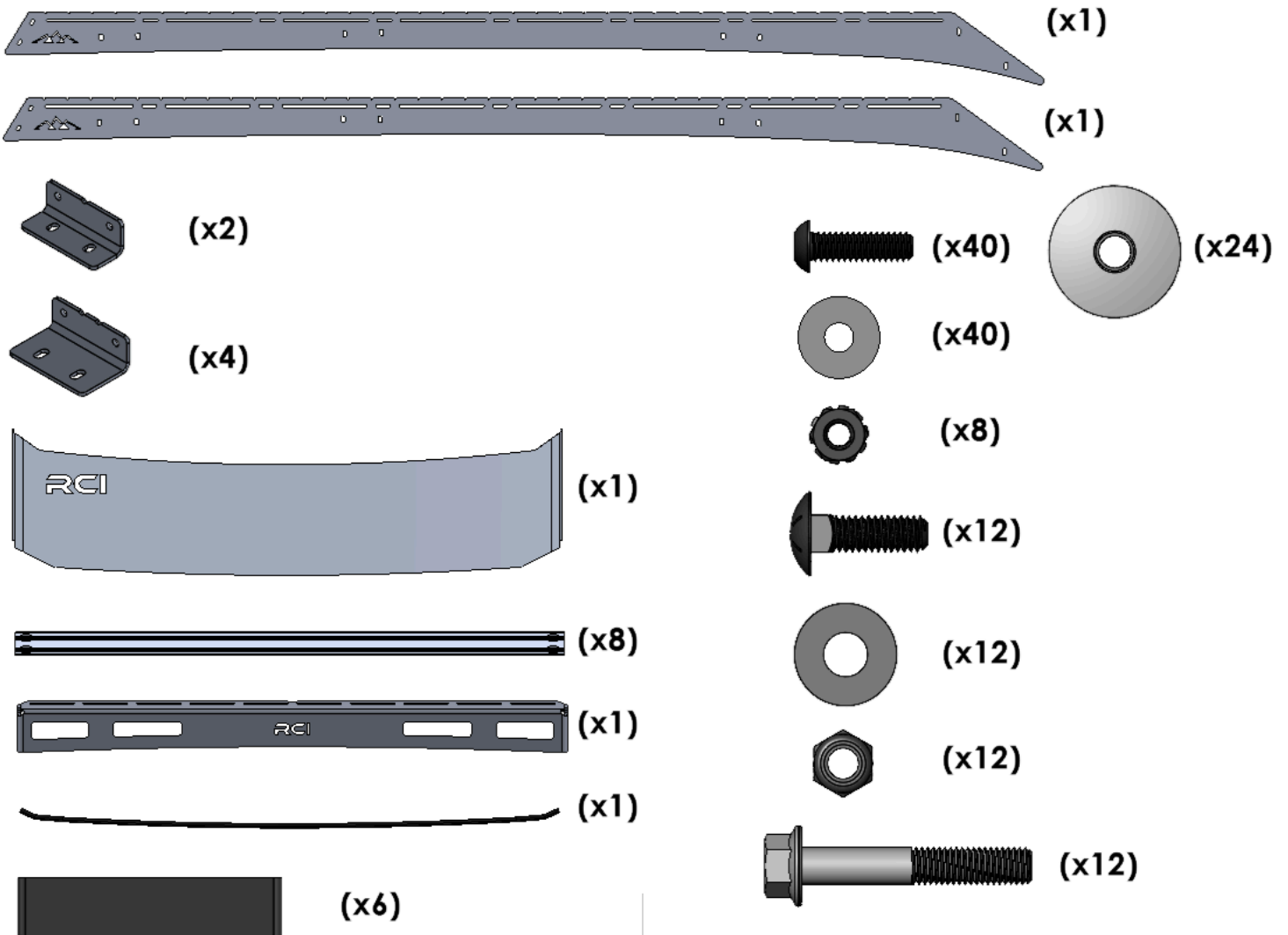

2. Remove the OEM roof rack if applicable to expose the factory M8 mounting locations.
3. Collect the six (6) rubber blocks and place them over the six factory mounting locations as depicted below.



4. On the ground, lay out the 47" Aluminum T-Slot cross bars and the driver / passenger side panels with the mountains facing the correct direction. (Driver top. Passenger bottom).

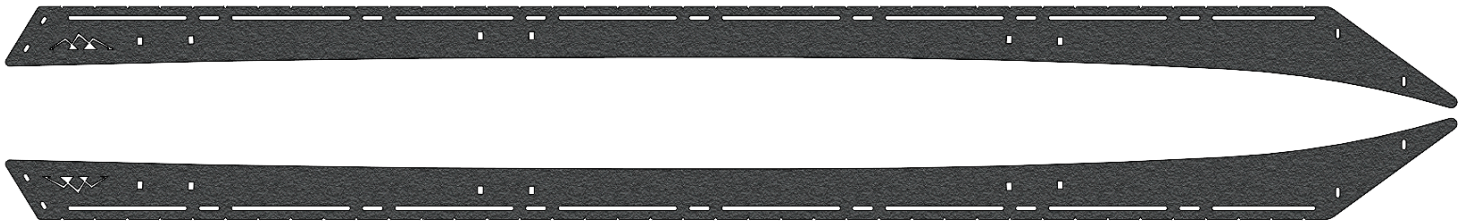

5. Collect the four (4) roof rack feet with the two identification notches. Install these feet in the two rear most mounting locations on the side panels using the 5/16" carriage bolts, 5/16" washers and 5/16" locknuts. Reference the image below.

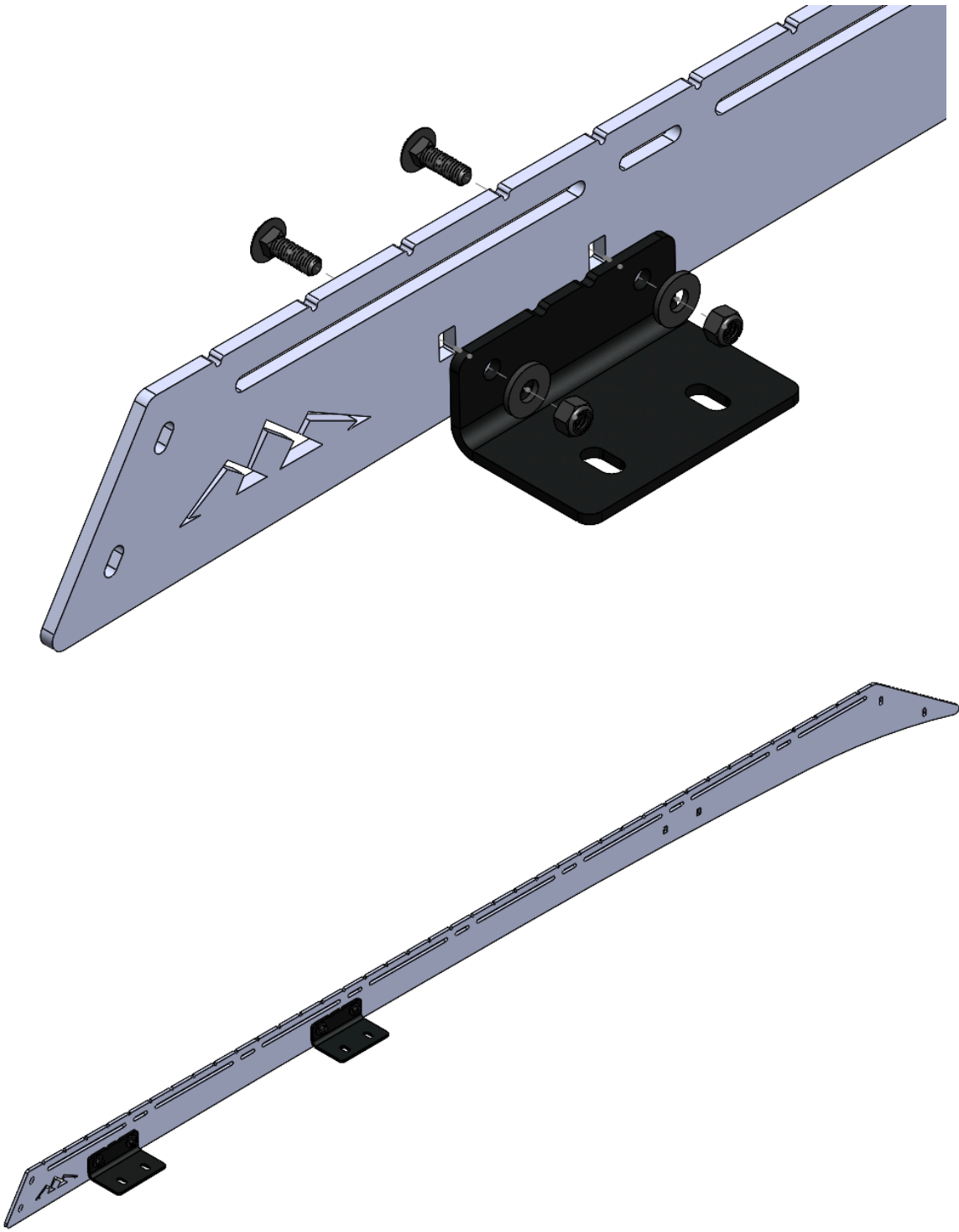

- Next collect the two (2) roof rack feet with the single identification notch. Install these feet in the front most mounting locations on the side panels using the 5/16" carriage bolts, 5/16" washers and 5/16" locknuts. Reference the image below.

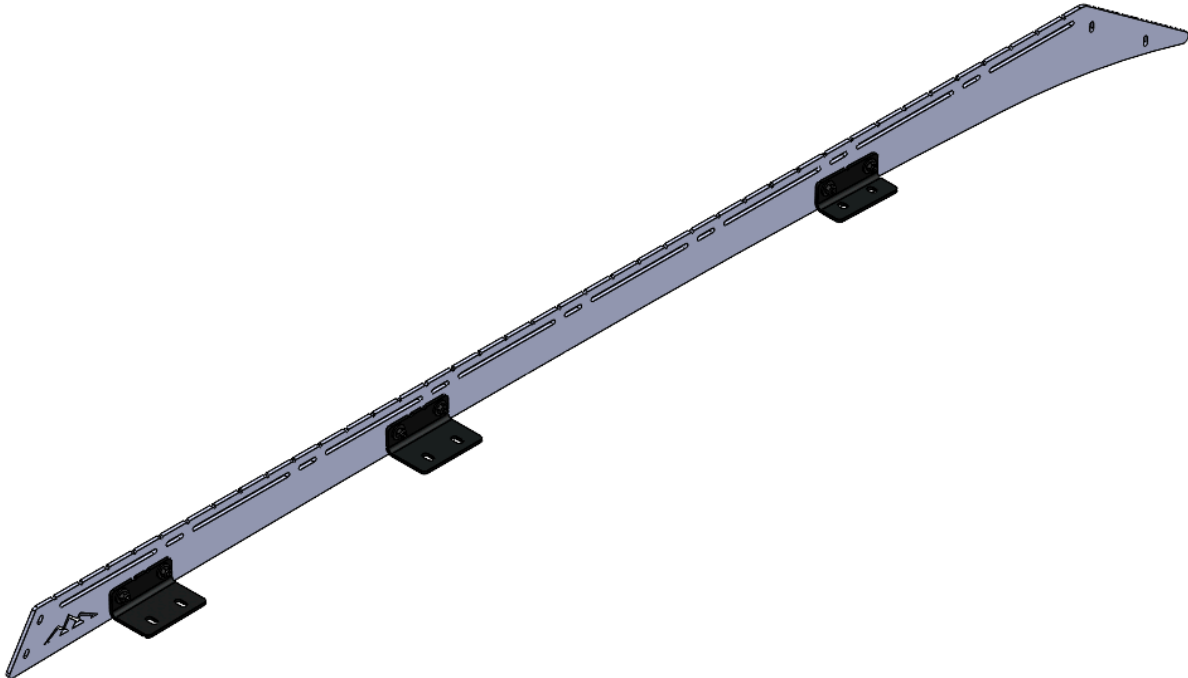
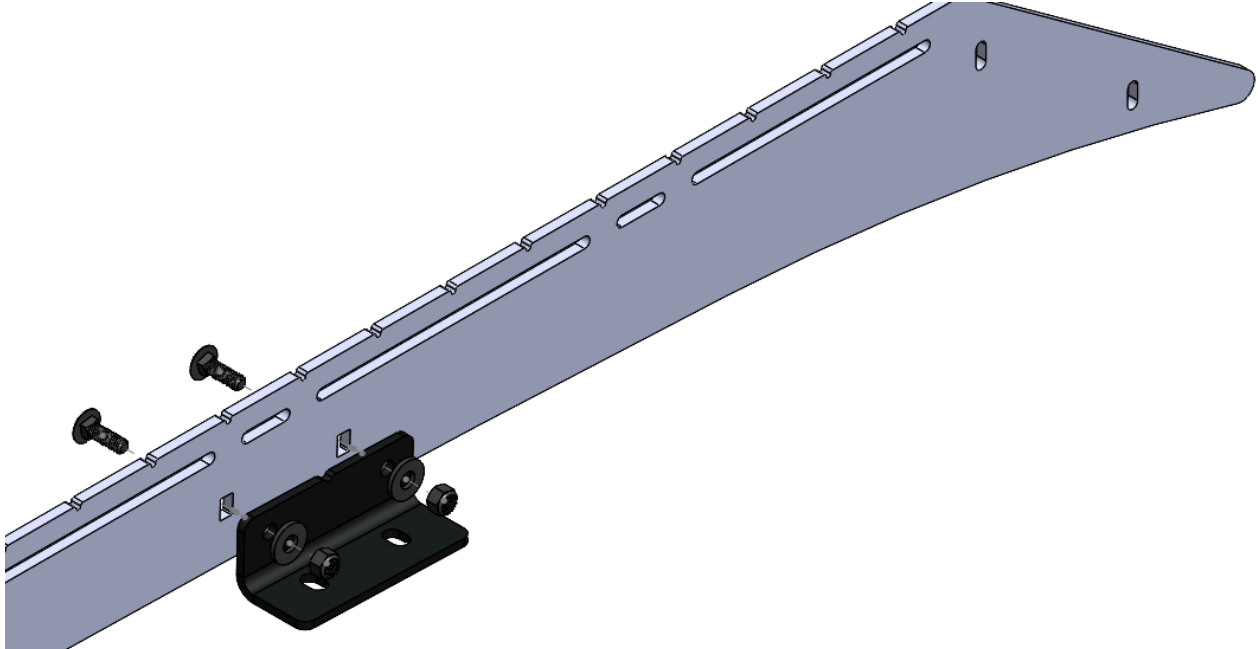

7. After all 6 mounting feet are installed, lay out the side panels on the ground and place the 47" T-slot cross bars in between them. Install the 8 crossmembers to the side panels using the provided 1/4-20 button heads and 1/4 " black washers.
 - a. NOTE: It is recommended to have the T-Slot top opening on the same side of the vehicle on all cross bars to make it easier to install accessories.
8. It is recommended to install the remaining crossbars in the 1" slots to ensure equal spacing
 - a. NOTE: Use hand tools to prevent stripping the heads of the 1/4-20 button heads.

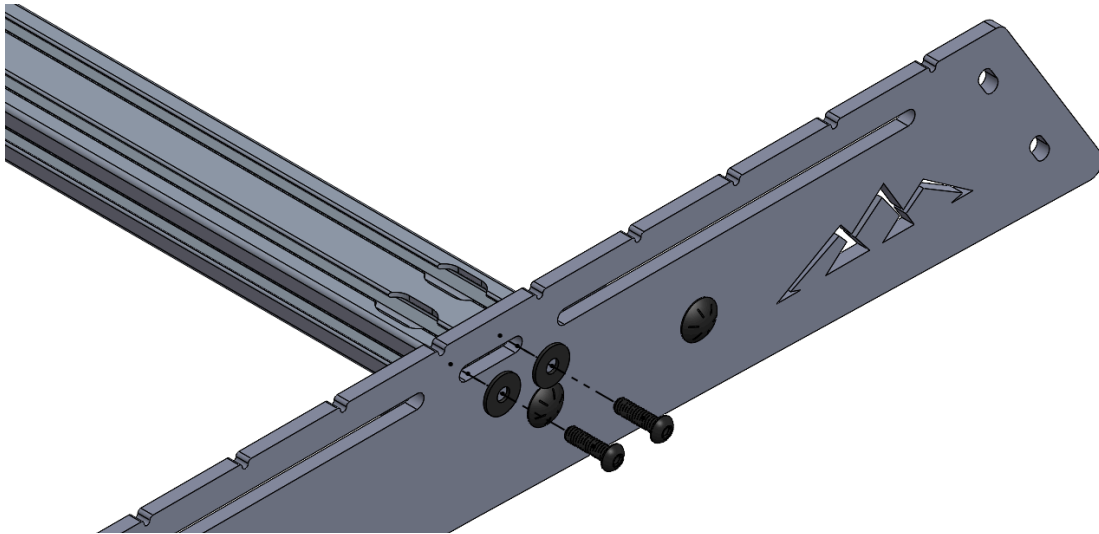

9. Collect and install the rear fairing using four (4) 1/4-20 button heads, four (4) 1/4" black washers, and four (4) black 1/4" keeps nuts.
 - a. Center the rear fairing in the slots on the side panels.

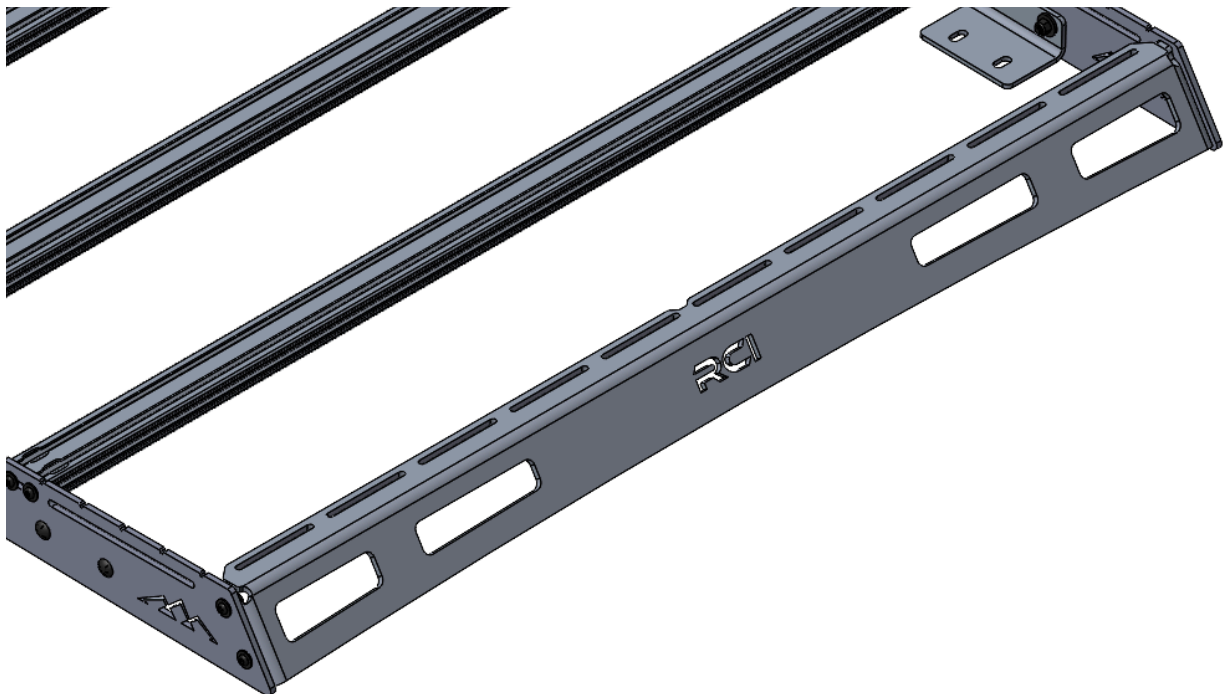
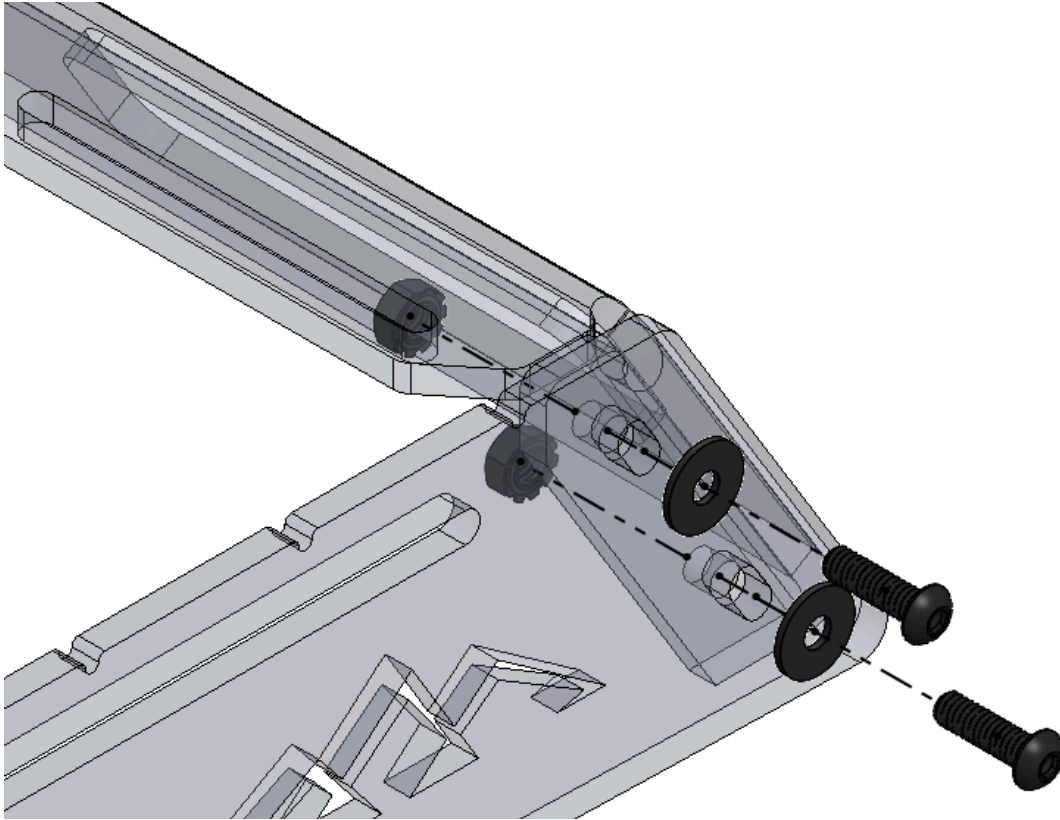

10. With the help of a friend, lift the rack onto the vehicle. Ensure all mounting feet are resting on the rubber blocks that were installed in step 3.
11. Collect twelve (12) M8 x 50mm flanged bolts and twelve (24) M8 x 1.125 bonded washers.
12. Instal the bolts with bonded washers through the bottom slots on the roof rack feet, through the holes on the rubber blocks, and threaded into the factory mount points.
 - a. NOTE: install a second bonded washer under the roof rack foot and above the rubber block. Make sure that the rubber side of the washer rests against the metal roof rack foot.

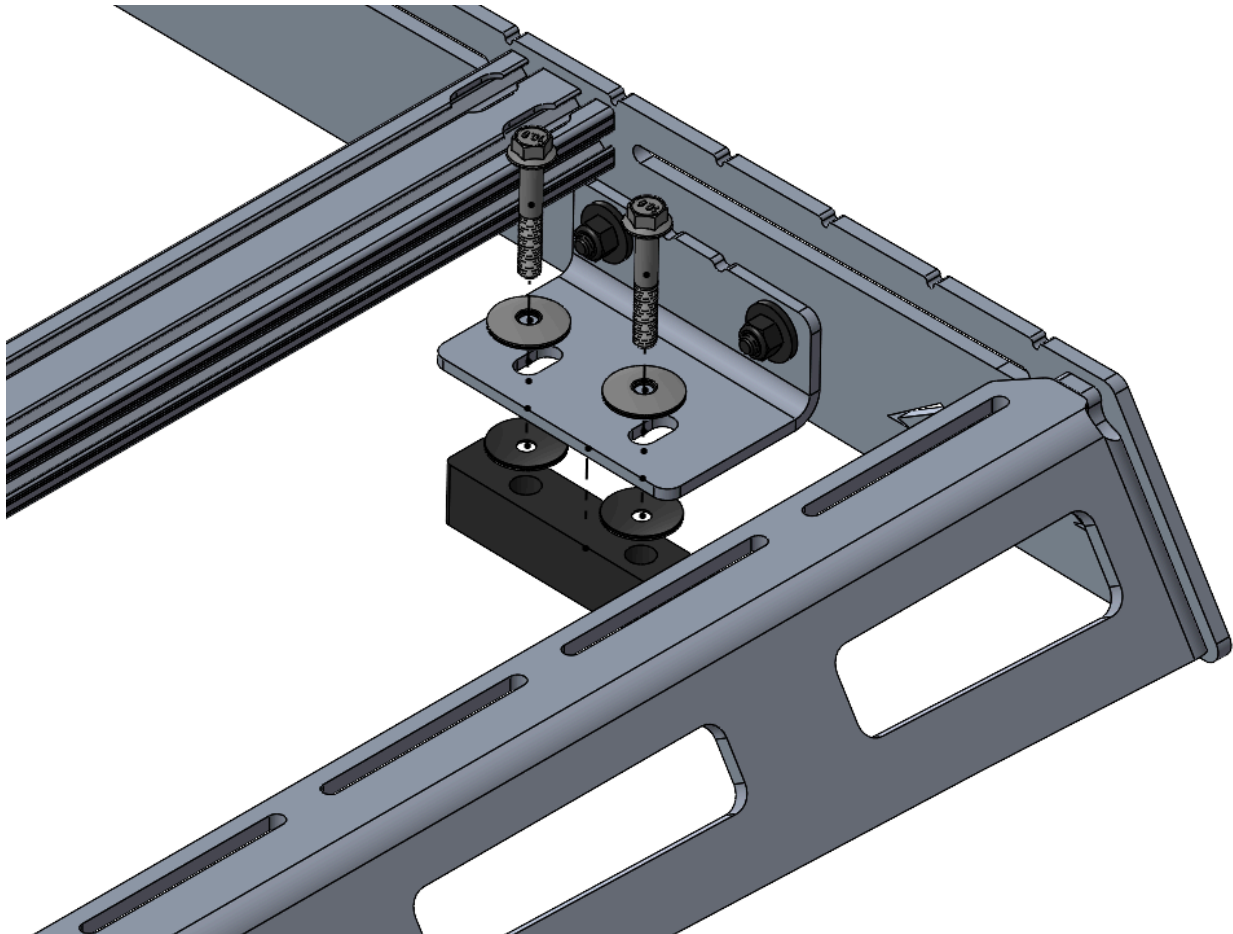

13. Loosely install all 12 bolts before fully tightening the roof rack.
14. Tighten all mounting locations to ensure a watertight seal.
 - a. NOTE: If needed, the 5/16" carriage bolts securing the feet to the rack can be loosened and adjusted up and down to achieve an even gap throughout the roof rack.

15. Collect the front fairing and install the weather strip on the bottom edge.
 - a. NOTE: A decent amount of pressure is required to seat the weather strip properly.



16. Collect the front fairing and four (4) 1/4-20 button heads, four (4) 1/4" black washers, and four (4) black 1/4" keeps nuts. Loosely install the fairing on the roof rack.
 - a. NOTE: When installing the front fairing, it is designed to bow towards the front of the truck. It is IMPORTANT to push the front fairing as far down as possible. It should be touching the roof of your truck.

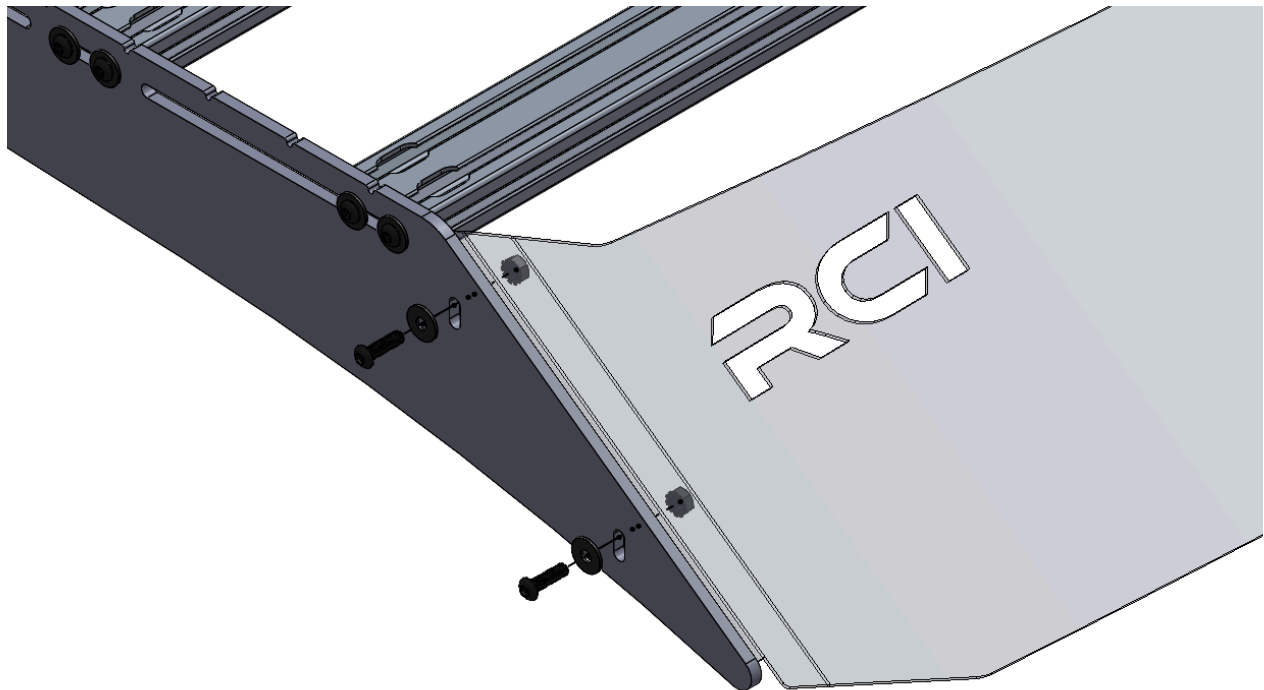



Enjoy your new RCI protection!



Share your new install with us on social media!

We love seeing our products out in the wild!

www.rcimetalworks.com

sales@rcioffroad.com

970-797-3089

REV: 1 | 9/29/2022

Disclaimer: The products sold by RCI Metalworks are intended for off-road use only, should not be modified, and are for use only on the vehicle(s) specifically stated. RCI Metalworks makes no warranties express or implied, including of fitness for a particular purpose or merchantability. RCI Metalworks will not be liable for any damages arising out of the use or misuse of its products. It is the customers' responsibility to ensure the products are safely and properly attached to the vehicle, and all products should be installed by trained professionals. We strive to maintain extremely high-quality standards; however, all RCI Metalworks products are individually handcrafted, may vary slightly, and may contain minor imperfections. Due to the nature of raw aluminum, the material may have minor scratches and other blemishes caused by the manufacturing process, especially on the back side of product. RCI Metalworks is constantly seeking to improve its products and reserves the right to make changes to any product.

