

4th Gen Tacoma Double Cab Short Bed Rock Slider Installation Guide

ITEM NO.	PART NUMBER	DESCRIPTION	QTY.	
1	SM-00774	.24+ Tacoma DCSB Slider Driver	1	
2	SM-00775	.24+ Tacoma DCSB Slider Passenger	1	
3	HW-00077	M10-1.25 X 30MM HEX FLANGE	16	
4	HW-00026	3/8 USS FLAT WASHER THRU HARD	16	
5	HW-00025	M8-1.25 X 30MM HEX FLANGE BOLT	2	
6	HW-00037	5/16 USS FLAT WASHER ZINC	2	
7	SM-00508	Tacoma Tread Plate Passenger	1	Included if tread plates are optioned
8	SM-00509	Tacoma Tread Plate Driver	1	
9	HW-00017	1/4-20 X 7/8 BUTTON SOC CAP BLACK	20	
10	HW-00019	1/4 SAE FLAT WASHER BLK ZINC	40	
11	HW-00031	1/4-20 KEPS NUT 18-8 S.S. BLACK	20	

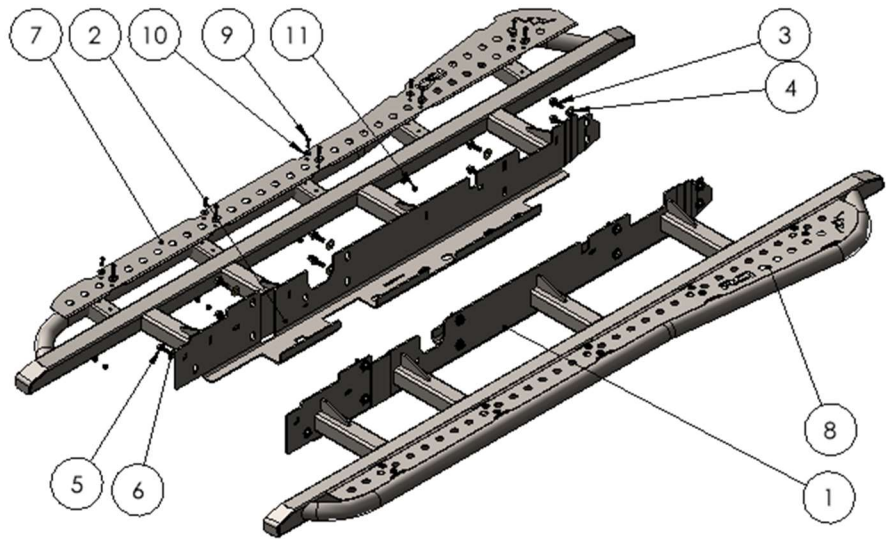

UNLESS OTHERWISE SPECIFIED:	PROPRIETARY AND CONFIDENTIAL	NAME	DATE
DIMENSIONS ARE IN INCHES TOLERANCES: FRACTIONAL ± 0.010 ANGULAR: BEND ± 0.5 TWO PLACE DECIMAL ± 0.015 THREE PLACE DECIMAL ± 0.010	THE INFORMATION CONTAINED IN THIS DRAWING IS THE SOLE PROPERTY OF RCI Offroad. ANY REPRODUCTION IN PART OR AS A WHOLE WITHOUT THE WRITTEN PERMISSION OF RCI Offroad IS PROHIBITED.	DRAWN	NA
		Export Date	
		4/30/2024	
RCI OFFROAD			
TITLE:			
2024 Tacoma Double Cab Short Bed Slider Install Guide			
Item Number		REV	
Default		1	
DO NOT SCALE DRAWING	SCALE: 1:32	WEIGHT:	SHEET 1 OF 1

Figure 1: BOM

INSTALLATION STEPS:

****Use hand tools, impact wrenches may cause damage if over torqued****

- 1) Begin by unpacking and removing all components and hardware. Please verify that all hardware and mounting components are present. Reference your original order invoice and verify all items are accounted for.
- 2) Prepare the trucks frame for slider installation by removing all plastic clips and disconnecting the ground wires present on the passenger side of the vehicle.
 - a. Use a flathead screwdriver or a clip removal tool to pry the plastic clips from the vehicle frame.

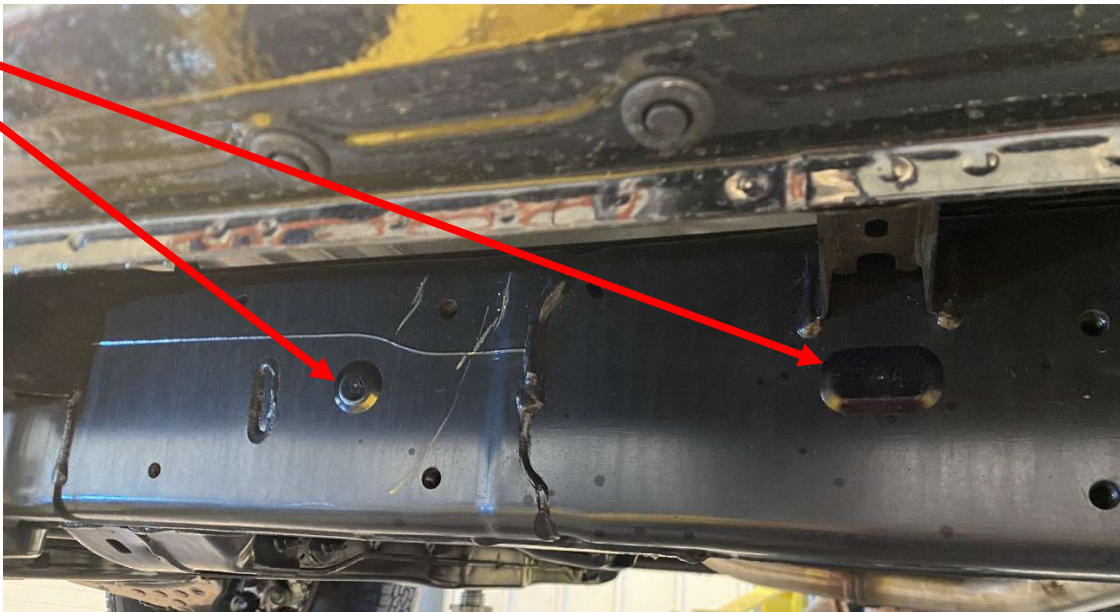

Figure 2: Example of plastic clips to remove.



Figure 3: Pry off the plastic clips.



Figure 4: Disconnect the ground wire on the passenger side.

- 3) Collect the driver side slider along with eight (8) M10x30mm bolts, eight (8) 3/8" washers, one (1) M8x30mm bolt, and one (1) 5/16" washer.

- 4) With the help of a floor jack or friend, lift the slider in place. Ensure that the slotted holes are aligning with the threaded holes on the frame.
- 5) Loosely install the M10x30mm bolts with 3/8" washers in the rear 8 mounting holes to help hold the slider in place.

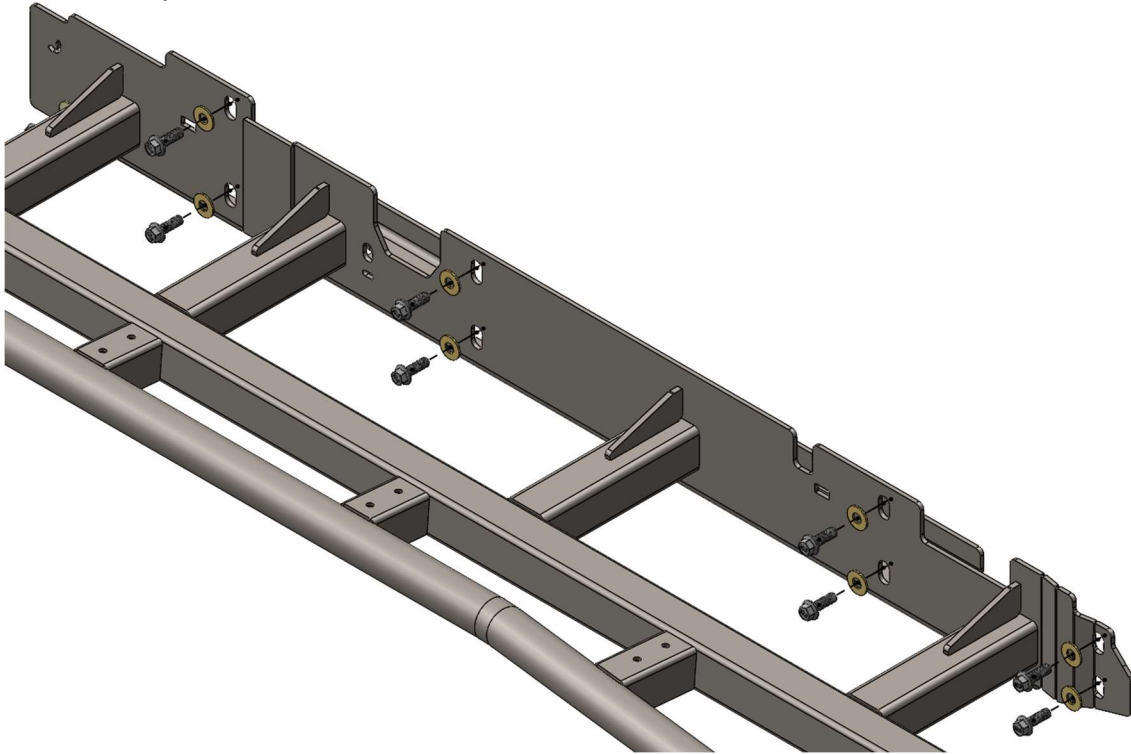

Figure 5: M10x30mm mounting locations.

- 6) Loosely install the M8x30mm bolt and 5/16" washer in the front most mounting hole.

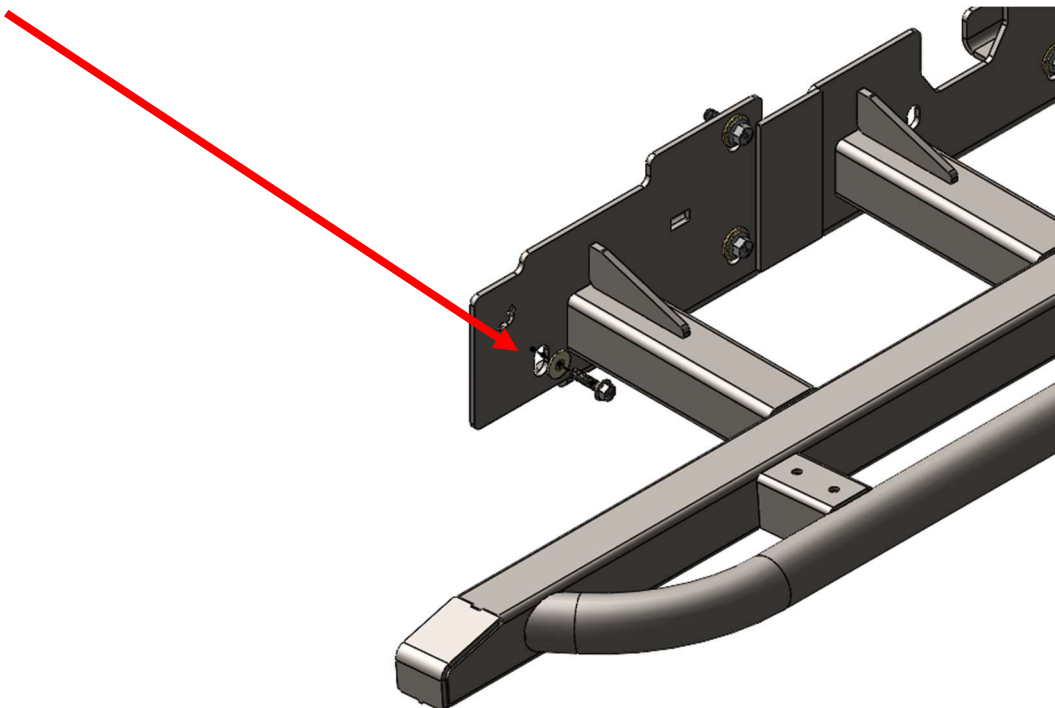

Figure 6: M8x30mm mounting location.

- 7) After all the hardware is loosely installed, push the slider up as high as possible and begin tightening all hardware.
 - a. Torque the M10 bolts to **60 ft-lbs.**
 - b. Torque the M8 bolt to **30 ft-lbs.**
- 8) Repeat steps 3-7 for the passenger side of the vehicle.
- 9) When installing the passenger side slider, make sure that the frame plate ground wire is reinstalled on top of the slider frame plate as depicted below.



Figure 7: Ground wire reinstalled correctly.



Figure 8: Correct installation of passenger side.

10) If installing tread plates, collect the appropriate side tread plate and install them with the provided 1/4-20 button head screws with 1/4" washers and 1/4-20 keps nuts.

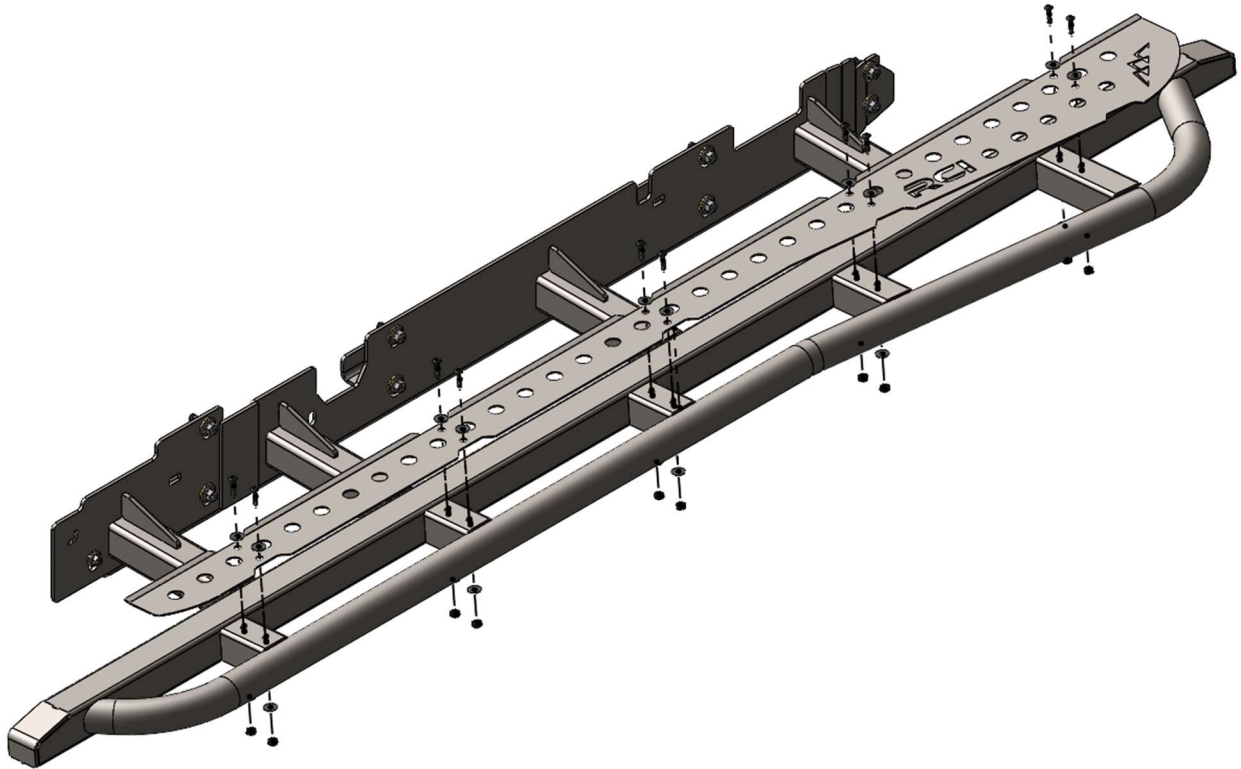

Figure 9: Tread plate installation.

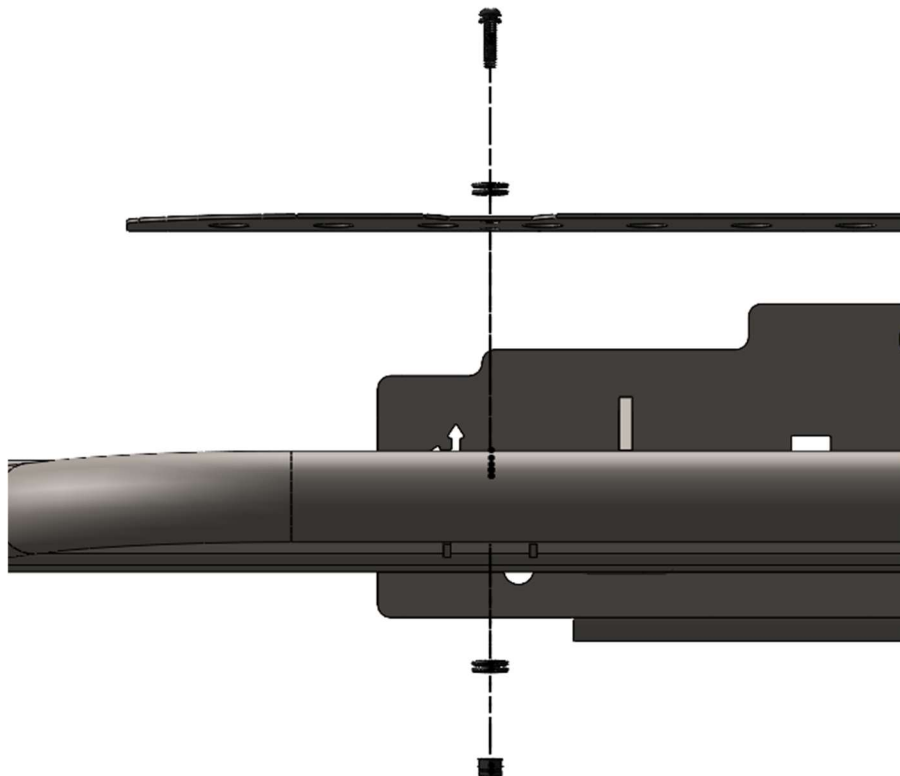

Figure 10: Hardware orientation.

Enjoy your new RCI protection!



Share your new install with us on social media!

We love seeing our products out in the wild!

www.rcimetalworks.com

sales@rcioffroad.com

970-797-3089



Disclaimer: The products sold by RCI Metalworks are intended for off-road use only, should not be modified, and are for use only on the vehicle(s) specifically stated. RCI Metalworks makes no warranties express or implied, including of fitness for a particular purpose or merchantability. RCI Metalworks will not be liable for any damages arising out of the use or misuse of its products. It is the customers' responsibility to ensure the products are safely and properly attached to the vehicle, and all products should be installed by trained professionals. We strive to maintain extremely high quality standards; however, all RCI Metalworks products are individually handcrafted, may vary slightly, and may contain minor imperfections. Due to the nature of raw aluminum, the material may have minor scratches and other blemishes caused by the manufacturing process, especially on the back side of product. RCI Metalworks is constantly seeking to improve its products and reserves the right to make changes to any product.