

RCI 19+ F150 SuperCrew SB Slider Install Guide

ITEM NO.	PART NUMBER	DESCRIPTION	QTY.
1	15+ F150 SuperCrew SB Sliders	Pair	1
2	15+ F150 SuperCrew SB Rear Bolt on Leg	Pair	1
3	07-21 Tundra Slider Tread Plates	Pair (If Selected in Invoice)	1
4	Tread Plate Hardware Kit	Included if Tread Plate is Added	1
5	Mounting Plate #1	Hardware(RCI)	8
6	M10 Speed Clip	Hardware	15
7	M10 X 35mm Flanged Bolt	Hardware	15
8	3/8" Washer	Hardware	21
9	3/8" Nut	Hardware	4
10	3/8" Split-Washer	Hardware	4
11	3/8" x 3.5" Carriage Bolt	Hardware	4
12	1/2" Washer	Hardware	3
13	M8 Speed Clip	Hardware	5
14	M8 x 30mm Mounting Bolt	Hardware	5

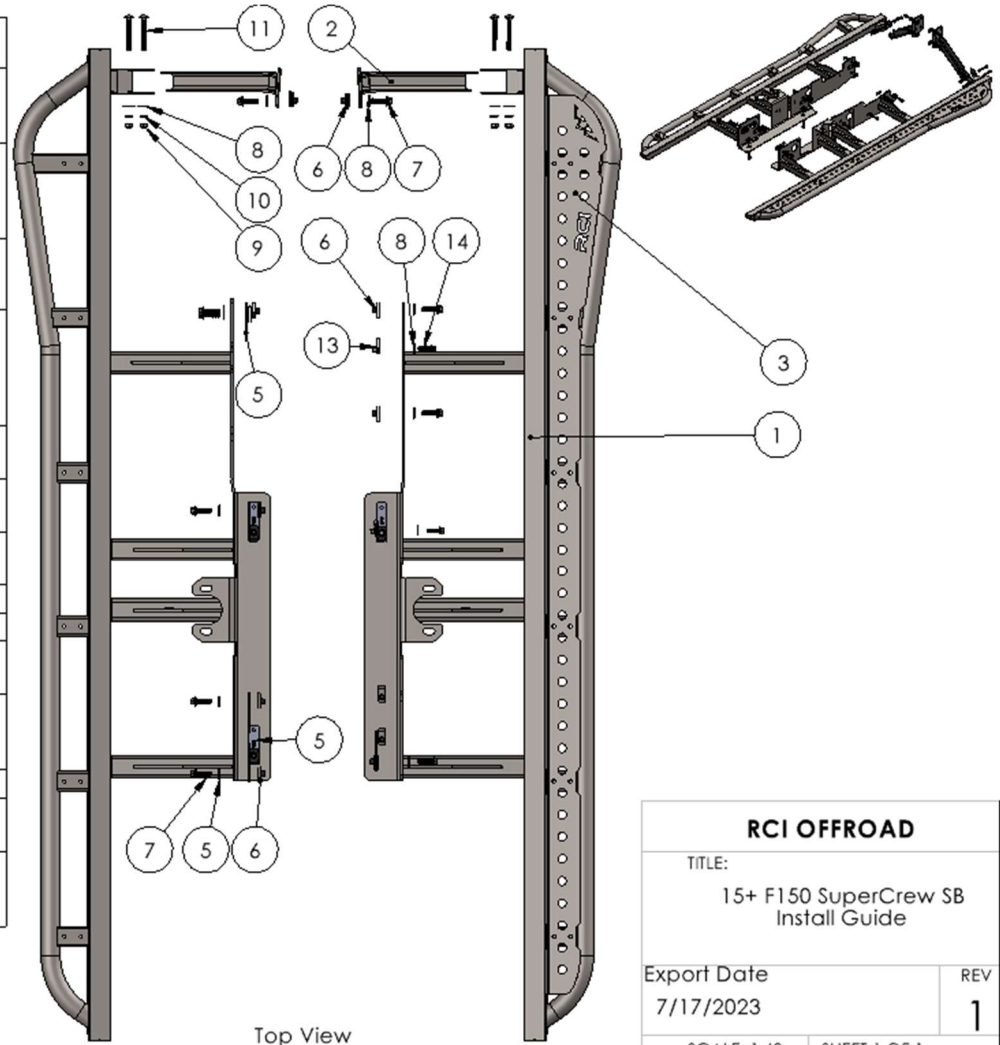

RCI OFFROAD	
TITLE: 15+ F150 SuperCrew SB Install Guide	
Export Date 7/17/2023	REV 1
SCALE: 1:48	SHEET 1 OF 1

INSTALLATION STEPS:

****Use hand tools, impact wrenches may cause damage if over torqued.****

- 1) **PLEASE NOTE:** Some F-150 model trucks have a fuel control box located on frame of the passenger side of the vehicles. If your F-150 does have the fuel control box, please reference **Appendix A** before continuing with the installation. Only the box depicted below needs to be relocated. If the box is further forward than the one below, then it does not need to be relocated.



Figure 1: Fuel Control Box

- 2) Begin by unpacking and removing all components and hardware. Please verify that all hardware and mounting components are present. Reference your original order invoice and verify all items are accounted for.
 - a. **PLEASE NOTE:** Sliders purchased with an RCI Black Powder Coat should be inspected thoroughly for any possible damage during shipment. Once the sliders have been mounted to the vehicle, RCI will no longer be able to assist with powder coat damage that may have occurred in transit.
 - b. Sliders purchased in Bare Metal should be cleaned with Acetone and covered in a rust preventative (powder coat, paint, bed liner, etc.) before mounting to the vehicle.

- 3) Start by removing all OEM rock rails or side steps from the truck.
- 4) If applicable, remove the factory transfer case skid plate. This skid can be reinstalled below the slider once installation is complete.
 - a. NOTE: OEM speed clips can be reused for slider installation. The hardware kit includes replacement speed clips if OEM hardware needs replaced.



Figure 2: OEM Transfer Case Skid to be Removed.

- 5) On the Driver and Passenger side of the vehicle, remove the two (2) center body mount nuts and save for reinstall later.

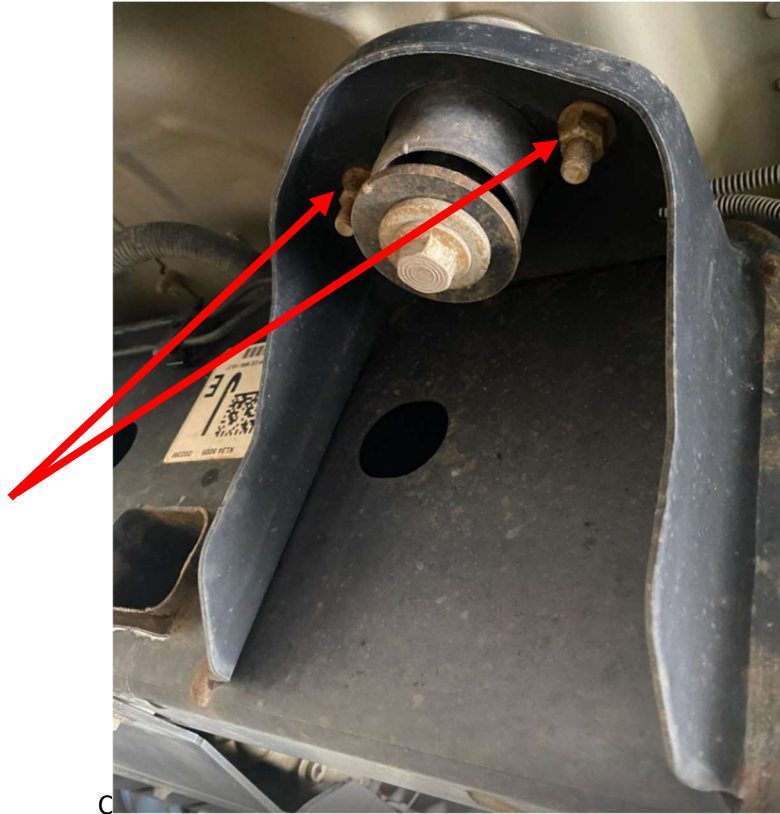

Figure 3: Body Mount Nuts to be Removed

- 6) Next, collect eight (8) Mounting Plate #1 and eight (8) M10 Speed Clips. Install the speed clips to the mounting plates as depicted below and save them for later use.

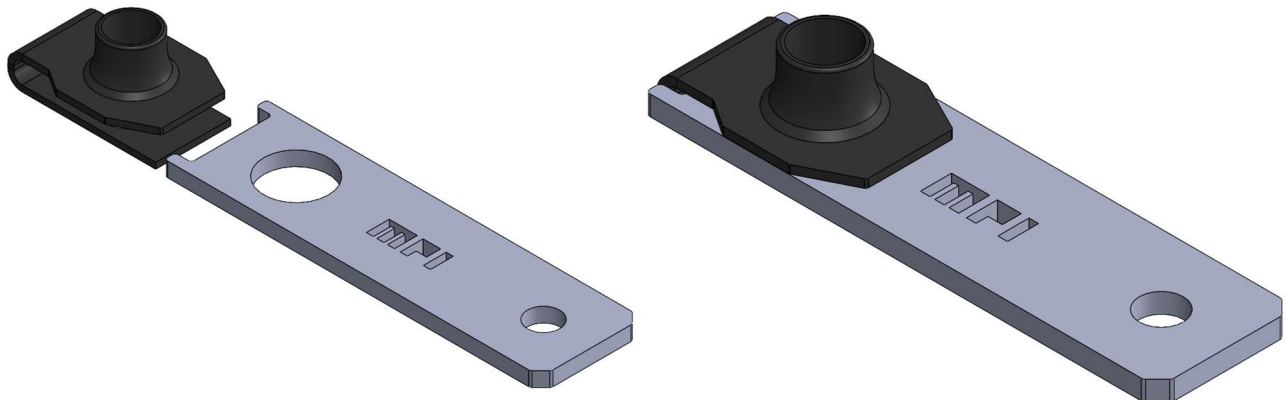

Figure 4: Correct Installation of Speed Clip on MP1

- 7) Beginning on the driver side, collect four (4) M10 Speed Clips and three (5) M8 Speed Clips.
- 8) Install the speed clips in the frame of the vehicle as depicted below.
- NOTE: Some F150 models have speed clip mounts in different locations. Install the speed clips where applicable, the slider will have some holes that will not be used due to the variation in frame hole locations.

M10
Hardware

M8
Hardware



Figure 5: Driver Side Frontmost Speed Clip Locations



Figure 6: Driver Side Rearmost Speed Clip Locations

- 9) Collect one (1) of the assembled mounting plates and one (1) M10 x 35mm Bolt. Install the mount plate into the opening on the bottom of the frame. Loosely thread in the M10 bolt to keep the plate in place.



Figure 7: Preinstallation of Lower M10 Bolt

- 10) With the speed clips installed, Lift the Driver Side Rock Slider into position. Begin threading the OEM body mount nuts to help secure the slider. The use of a floor jack, stool, or a helping hand is recommended until fasteners are installed.
 - a. NOTE: all hardware needs to be loosely tightened until all hardware is installed.

- 11) Next collect two (2) M8 Bolts with two (2) 3/8" Washers and install them in the two front most mounting locations on the underside of the frame.

Remove the rearmost M10 bolt and reinstall it with a 1/2" Washer.

M10
Hardware

M8
Hardware

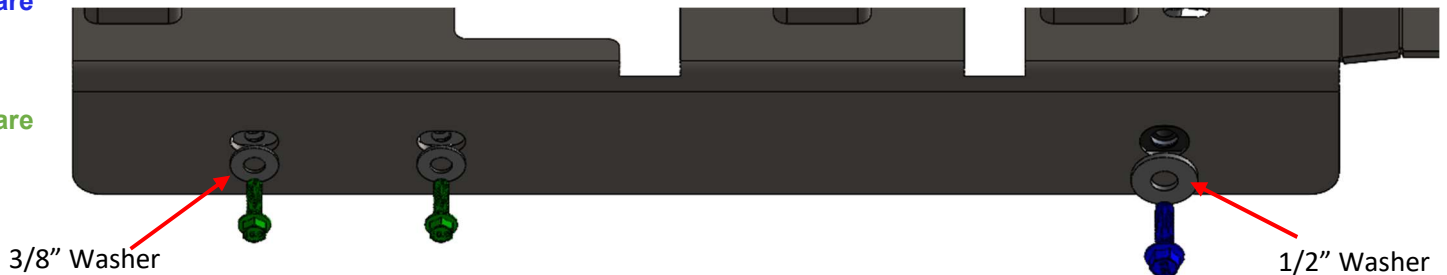

Figure 8: Driver Side Lower Mounting Locations

- 13) Working from front to back, collect one (1) of the assembled mounting plates, one (1) M10 Bolt, and one (1) 3/8" Washer.
Feed the mounting plate into the frame through the opening in the frame plate and align it with the mounting hole on the slider. Install the M10 bolt and 3/8" washers as depicted below.

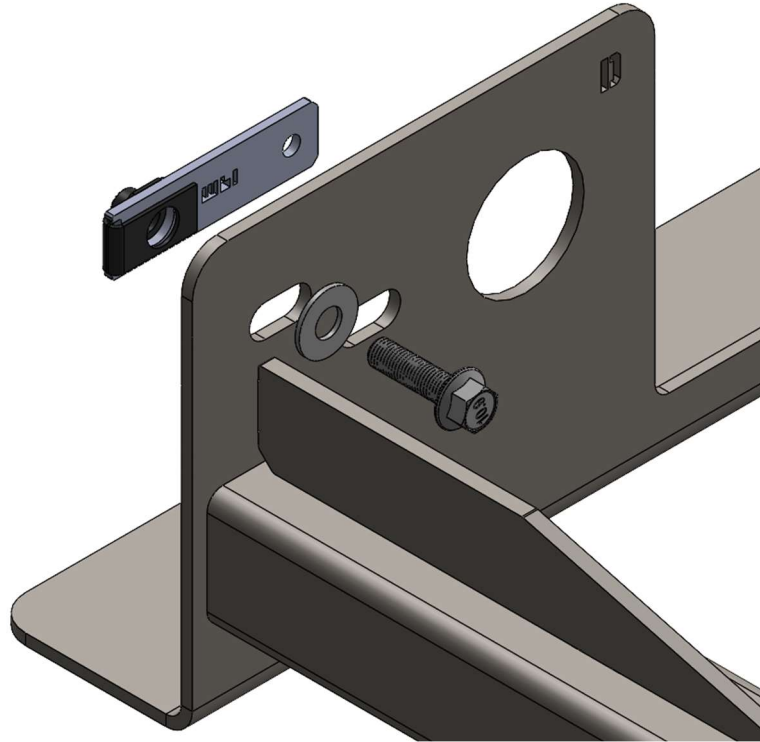

Figure 9: Driver Side Frontmost Mounting Location

- 14) Collect two (2) M10 Bolts, five (5) 3/8" Washers and three (3) M8 Bolts.
- 15) Install all hardware into the previously installed speed clips to secure the slider to the frame of the vehicle.
 - a. NOTE: There may be extra hardware due to variation in F150 frames. Install hardware where mounting is available.

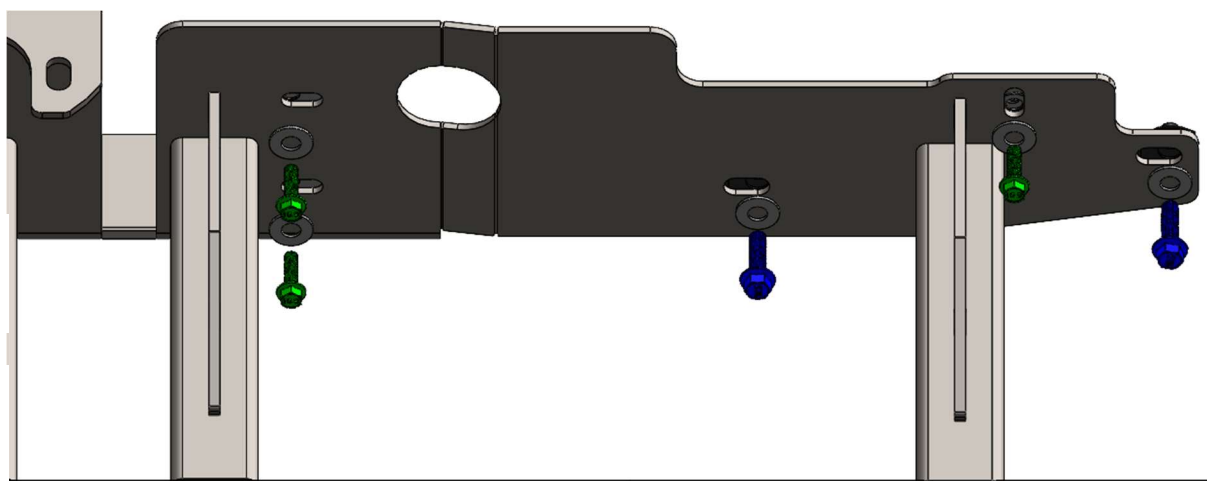

Figure 10: Example of Mounting Possibility

- 16) Collect the Driver Side Rear Bolt on Leg, two (2) 3/8" x 3 1/2" Carriage Bolts, five (5) 3/8" Washers, two (2) 3/8" Split Washers, two (2) 3/8" Nuts and two (2) M10 Bolts.

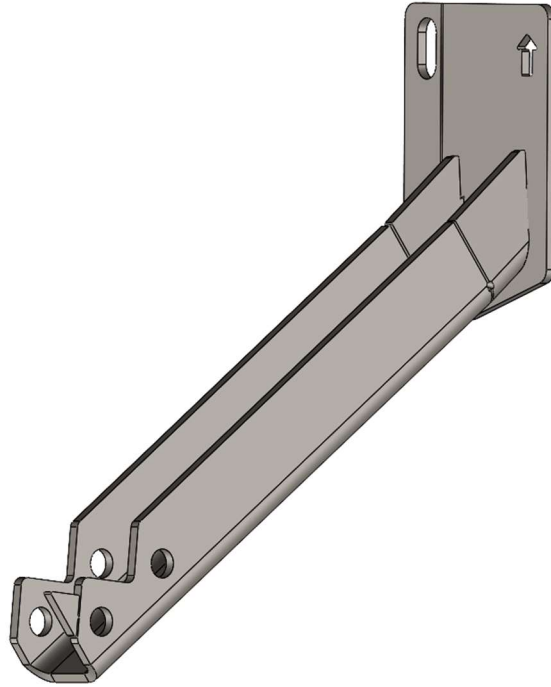

Figure 11: Driver Side Bolt on Leg

- 17) Feed the Rear Bolt on Leg in between the tabs on the rear of the slider main rail. Loosely secure it to the slider with the 3/8" carriage bolts, washers, lock washers and nuts as depicted below.
- NOTE: Install the carriage bolts so that the threads face the front of the vehicle.

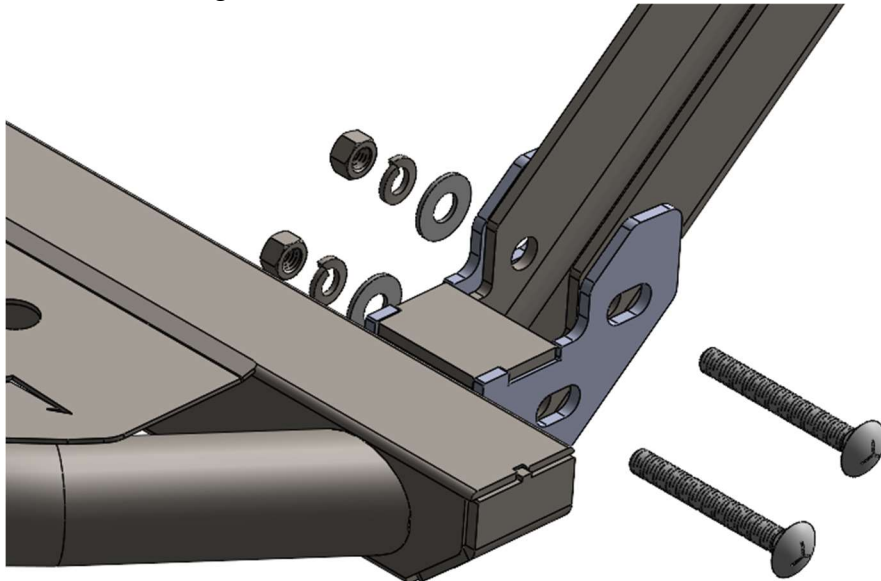

Figure 12: Correct Installation of Bolt on Leg

18) With the Bolt on Leg loosely installed, collect the two (2) M10 bolts with 3/8" washers and thread them into the two holes on the frame plate into the previously installed M10 speed clips.

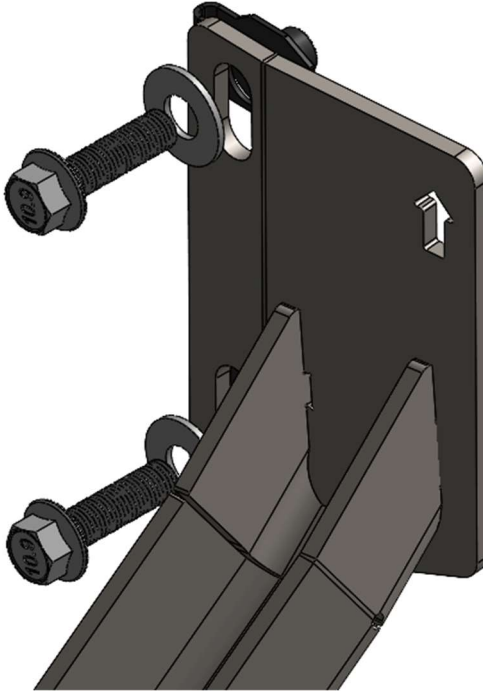

Figure 13: Correct Installation of Bolt on Leg

19) With all hardware loosely installed, go through and snug down all hardware so that the slider is mounted flush against the frame of the vehicle.

20) Move to the passenger side of the vehicle and collect four (4) M10 Speed Clips.

21) Install the speed clips in the frame of the vehicle as depicted below.

- a. NOTE: Some F150 models have speed clip mounts in different locations. Install the speed clips where applicable, the slider will have some holes that will not be used due to the variation in frame hole locations.

M10
Hardware



Figure 14: Passenger Side Speed Clip Locations



Figure 15: Passenger Side Rearmost Speed Clip Locations

22) Collect two (2) of the assembled mounting plates and two (2) M10 x 35mm Bolts. Install the mount plate into the openings on the bottom of the frame. Loosely thread in the M10 bolt to keep the plate in place.



Figure 16: Preinstallation of Lower M10 Bolt

23) With the speed clips installed, Lift the Passenger Side Rock Slider into position. Begin threading the OEM body mount nuts to help secure the slider. The use of a floor jack, stool, or a helping hand is recommended until fasteners are installed.

- a. NOTE: all hardware needs to be loosely tightened until all hardware is installed.

24) Next, remove the two M10 bolts and reinstall them with 1/2" Washers.

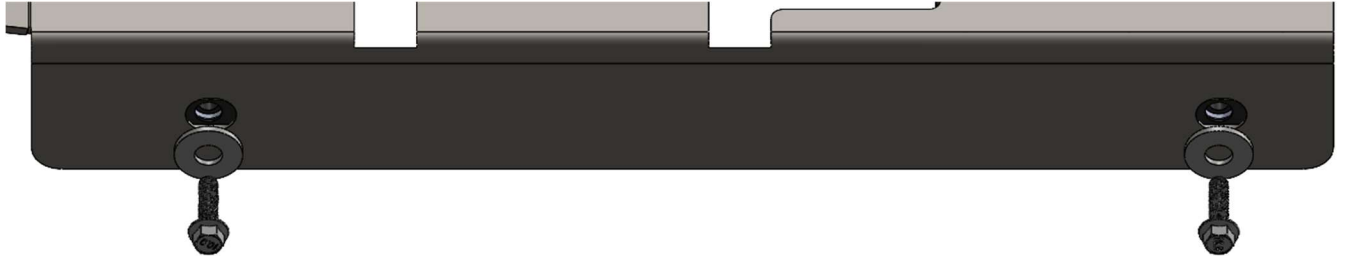

Figure 17: Passenger Side Lower Mounting Locations

25) Working from front to back, collect two (2) of the assembled mounting plates, two (2) M10 Bolts, and two (2) 3/8" Washers. Feed the mounting plate into the frame through the opening in the frame plate and align it with the mounting hole on the slider. Install the M10 bolts and 3/8" washers as depicted below.

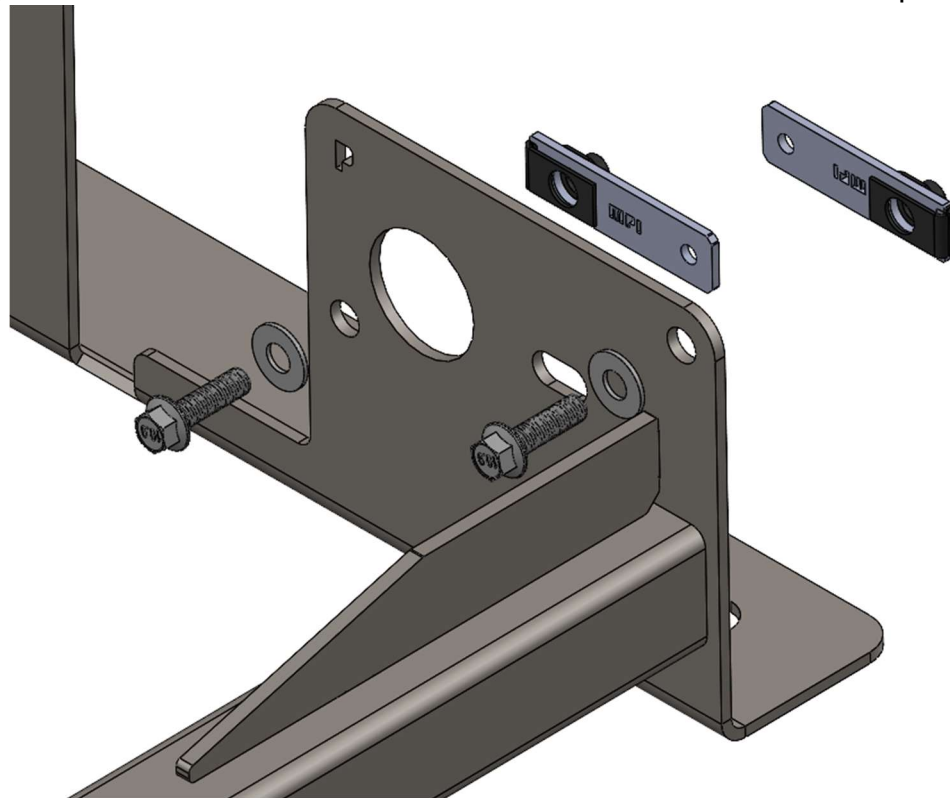

Figure 18: Passenger Side Frontmost Mounting Locations

26) Collect two (2) of the assembled mounting plates, three (3) M10 Bolts, and three (3) 3/8" Washers. Feed the two mounting plates into the frame through the opening in the frame plate and align it with the mounting hole on the slider. Install the M10 bolts and 3/8" washers as depicted below.

27) Install the third M10 bolt and 3/8" washer through the hole that aligns with the previously installed M10 speed clip.

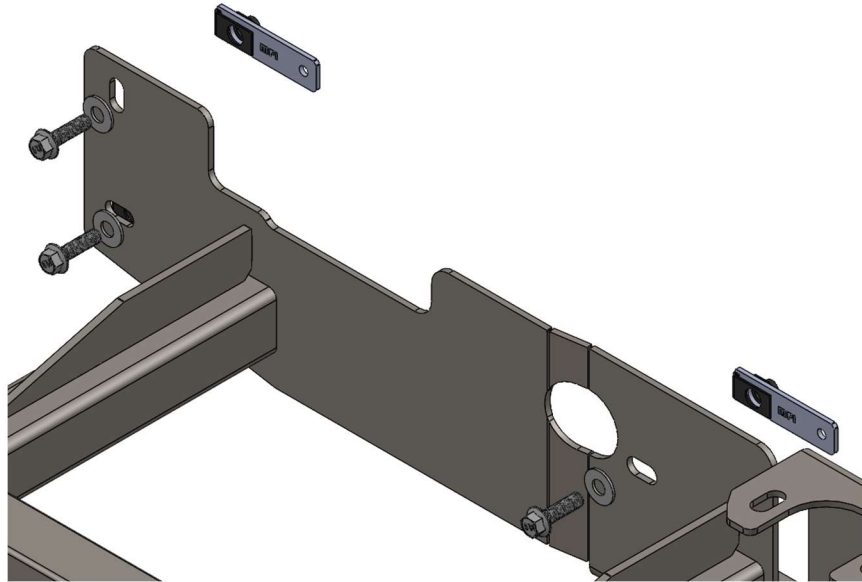

Figure 19: Passenger Side Rearmost Mounting Locations

28) Complete the passenger side installation by repeating steps 15-18 of the install guide.

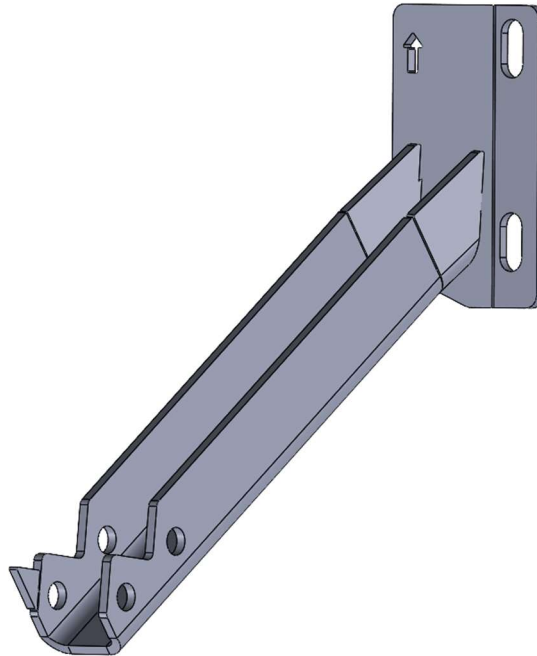

Figure 20: Passenger Side Bolt on Leg



Enjoy your new RCI protection!



**Share your new install with us on social media!
We love seeing our products out in the wild!**

www.rcimetalworks.com

sales@rcioffroad.com

970-797-3089

REV: 1 | 9/29/2022



Disclaimer: The products sold by RCI Metalworks are intended for off-road use only, should not be modified, and are for use only on the vehicle(s) specifically stated. RCI Metalworks makes no warranties express or implied, including of fitness for a particular purpose or merchantability. RCI Metalworks will not be liable for any damages arising out of the use or misuse of its products. It is the customers' responsibility to ensure the products are safely and properly attached to the vehicle, and all products should be installed by trained professionals. We strive to maintain extremely high quality standards; however, all RCI Metalworks products are individually handcrafted, may vary slightly, and may contain minor imperfections. Due to the nature of raw aluminum, the material may have minor scratches and other blemishes caused by the manufacturing process, especially on the back side of product. RCI Metalworks is constantly seeking to improve its products and reserves the right to make changes to any product.

APPENDIX A:

Fuel Control Box Relocation Instructions

- 1) Begin by removing the protective cover from the fuel control box.



Figure 17: Protective Cover to Remove

- 2) With the cover removed, unbolt the fuel control unit, and remove the threaded studs from the frame.
- 3) Reinstall the threaded studs towards the front of the frame in the 3 slots depicted below.



Figure 18: Slots for Threaded Stud Reinstallation

- 4) Reinstall fuel control unit and the protective cover in the new location.



Figure 19: Correct Relocation of Fuel Control Box