

RCI 16-23 Toyota Tacoma Arapaho Bumper Install Guide

ITEM NO.	PART NUMBER	DESCRIPTION	QTY.
1	SM-00556	.188MS Tacoma Front Bumber - Main Shell Gusset - R9	2
2	SM-00557	.188 MS - Tacoma Front Bumper - Winch Plate - R8	1
3	SM-00558	.188 MS Tacoma HYB Front - Horizontal Gusset - P1	1
4	SM-00559	.105 MS Tacoma Front Bumper - Come Up Winch Controller Mount - R3	1
5	SM-00600	.188 MS Tacoma Front Bumper - Center Section - R7	1
6	SM-00601	.188 MS Tacoma Front Bumper - Large Side Panels - R9	1
7	SM-00602	.188 MS Tacoma Front Bumper - Small Side Panels - R8	1
8	SM-00603	.188 MS Tacoma Front Bumper - Bumper Tips - R8	1
9	SM-00056	Mini Light Bar Tabs	2
10	SM-00456	.75 MS Tacoma Front Bumper - Shackle Mount - R3	2
11	TB-00084<As Machined>	Full Hoops R3	1
12	SM-00604	Mirror.188 MS Tacoma Front Bumper - Large Side Panels - R6	1
13	SM-00605	Mirror.188 MS Tacoma Front Bumper - Small Side Panels - R5	1
14	SM-00606	Mirror.188 MS Tacoma Front Bumper - Bumper Tips - R5	1

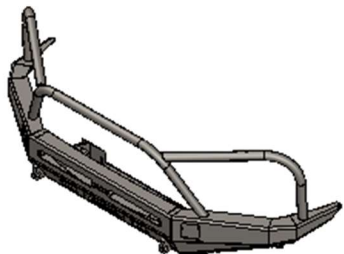

UNLESS OTHERWISE SPECIFIED:	PROPRIETARY AND CONFIDENTIAL	DRAWN	NAME	DATE
DIMENSIONS ARE IN INCHES FRACTIONS: 1/32, 1/16, 1/8, 1/4, 3/8, 1/2, 5/8, 3/4, 7/8 DECIMALS: 2 PLACES TOLERANCES: FRACTIONS: ±.0010 DECIMALS: ±.0010	THE INFORMATION CONTAINED IN THIS DRAWING IS THE SOLE PROPERTY OF RCI OFFROAD. ANY REPRODUCTION IN PART OR AS A WHOLE WITHOUT THE WRITTEN PERMISSION OF RCI OFFROAD IS PROHIBITED.			Export Date 3/25/2024
RCI OFFROAD				
TITLE BOM_TACO-16- ARAPAH0-FULLHOOPS- RAW BOM				
Item Number FG-00335			REV 1	
DO NOT SCALE DRAWING		SCALE 1:24	WEIGHT:	SHEET 1 OF 1

Figure 1: BOM

INSTALLATION STEPS:

****Use hand tools, impact wrenches may cause damage if over torqued.****

- 1) Begin by unpacking and removing all components and hardware. Please verify that all hardware and mounting components are present. Reference your original order invoice and verify all items are accounted for.
- 2) Identify and mark the cut lines for the OEM bumper.
 - a. Remove the fog lights, grille, and the plastic fog light housing covers from the OEM bumper. Remove the bolts and clips securing the fender liner to the OEM bumper.
 - b. Following the upper edge of the fog light pocket on the passenger side of the vehicle, run a piece of painter's tape towards the wheel well.
 - i. Measure points to identify the correct cut line.
 1. Mark the bumper 6" below the corner of the seam between the front quarter panel and the OEM bumper.

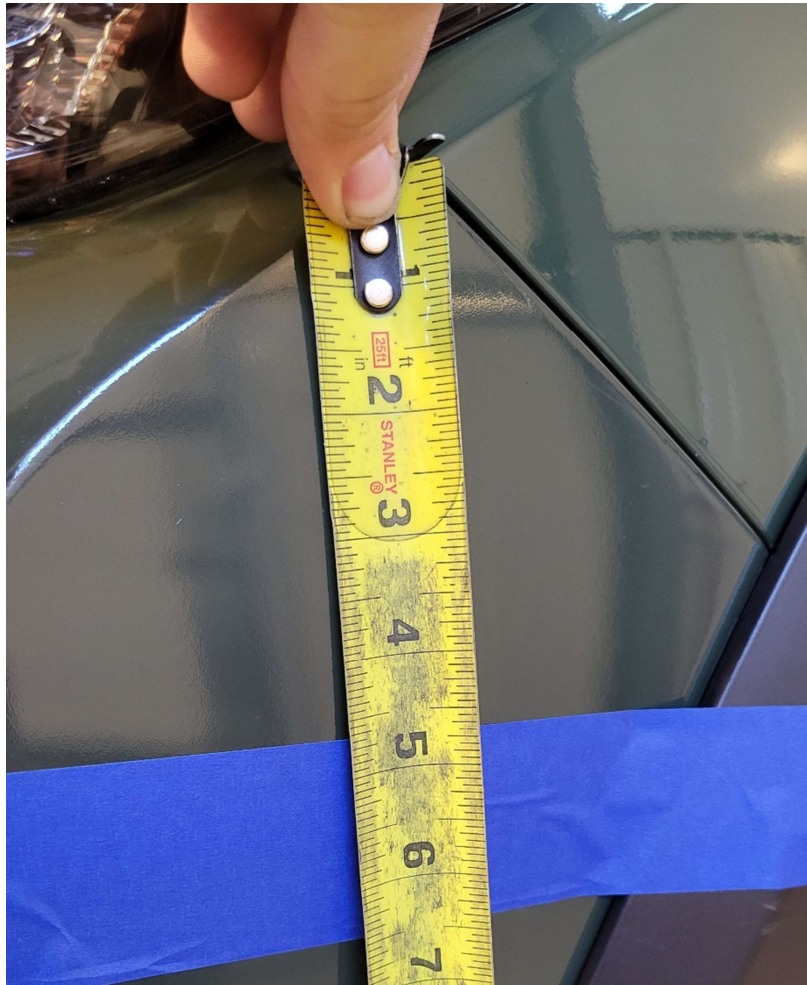

Figure 2: Mark Location

2. Mark the bumper 3+1/8" down the fender flare at the corner where the fender flare, OEM bumper, and front quarter panel meet.



Figure 3: Mark Location

- ii. Take special care to ensure that the edge of the tape is parallel and colinear with the upper edge of the fog light pocket. This edge will mark the cut line, so it is very important that the edge of the tape is laid as perfectly as possible.
- iii. Use of a laser level to verify the cut line, then following the laser line with the edge of the tape will lead to a much more true and precise line.
- iv. If concerns about the perfection of the marked cut line or the ability to follow the cut line perfectly exist, consider marking a secondary cut line 1/8" or more below the marked cut line and following the secondary line instead. Follow the steps to cut the secondary cut line, perform an initial installation of the RCI Arapaho front bumper, and verify that the gap between the RCI bumper and the cut OEM bumper is even across the length of the bumper. Adjust the cut line and/or technique as necessary before performing the final cut.



Figure 4: Secondary cut line shown

- c. Unplug the fog lights and verify that the cutting area is clear of any components that may interfere with, or be damaged by, the cutting of the OEM bumper.
 - i. The only components that should be cut in step 2c are the OEM bumper, the OEM fender flare, and the plastic mounting bracket securing the outer edge of the OEM bumper to the vehicle. All other components should be removed or relocated to avoid the cut area before proceeding.
- d. Use a Dremel, angle grinder with cutoff wheel, reciprocating saw, or similar cutting tool to make the cut. Make the cut below the cut line and use a file, flap disk, or other similar sanding tool to clean up the cut and carefully bring the cut edge up to the marked cut line.



Figure 5: Partially completed passenger side cut

- e. Repeat steps 2a through 2c on the driver side of the vehicle.

RCI OFF ROAD

- f. Remove the bolts and brackets securing the bottom of the OEM bumper to the aluminum crash bar assembly.
- g. Remove the black plastic OEM bumper insert from the bumper to allow the cut portion of the OEM to be removed from the vehicle.



Figure 6: Completed cut on driver side

- 3) Remove the aluminum crash bar assembly from the vehicle.
 - a. Remove the six nuts securing the aluminum crash bar to the mount posts. Remove the crash bar.

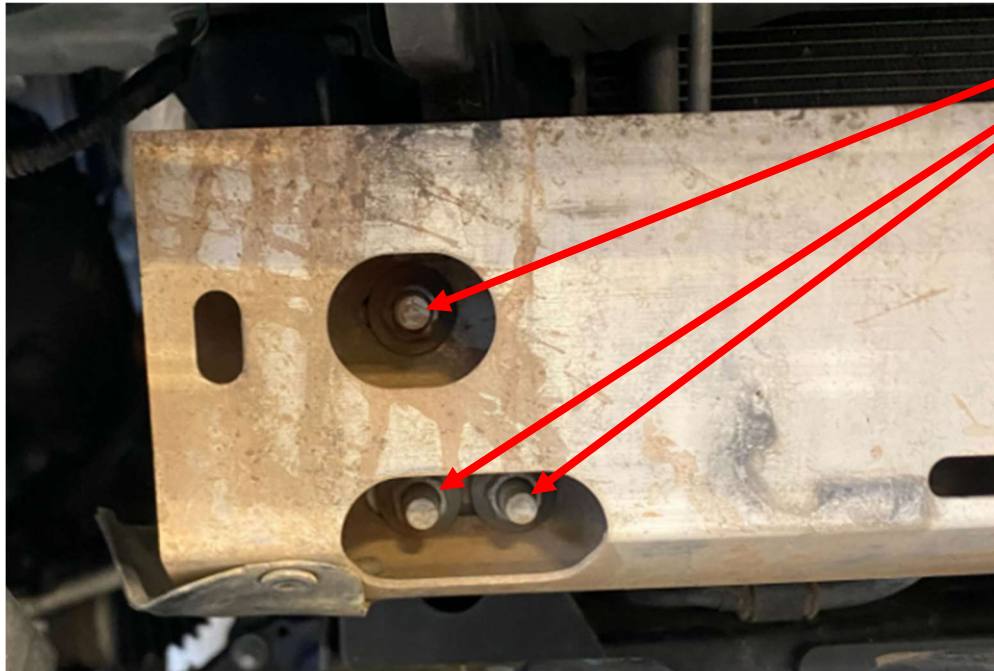

Factory nuts to be removed

Figure 7: Crash bar bracket nut locations

- b. Remove the six nuts securing the aluminum crash bar mount posts to the vehicle. Remove the posts.

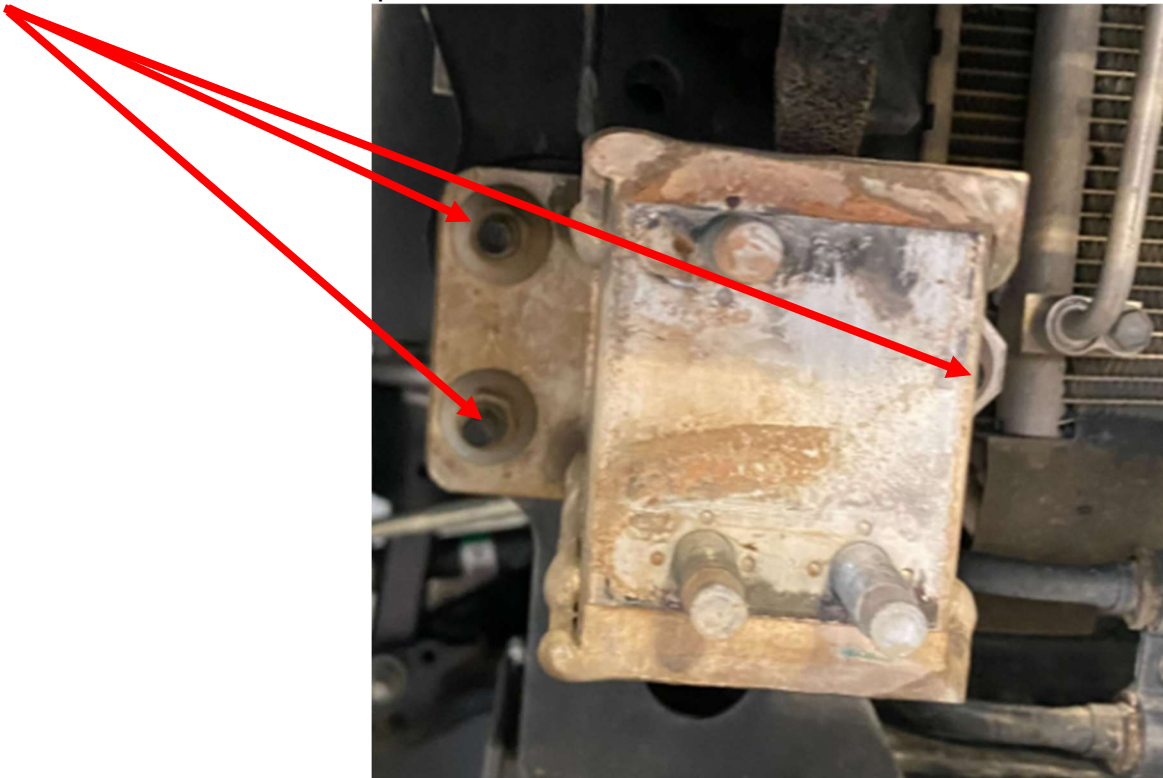

Figure 8: Crash bar bracket nut locations

- 4) Relocate the power steering line.
 - a. Remove the three bolts mounting the power steering cooler.

Mount behind front passenger wheel well splash guard.

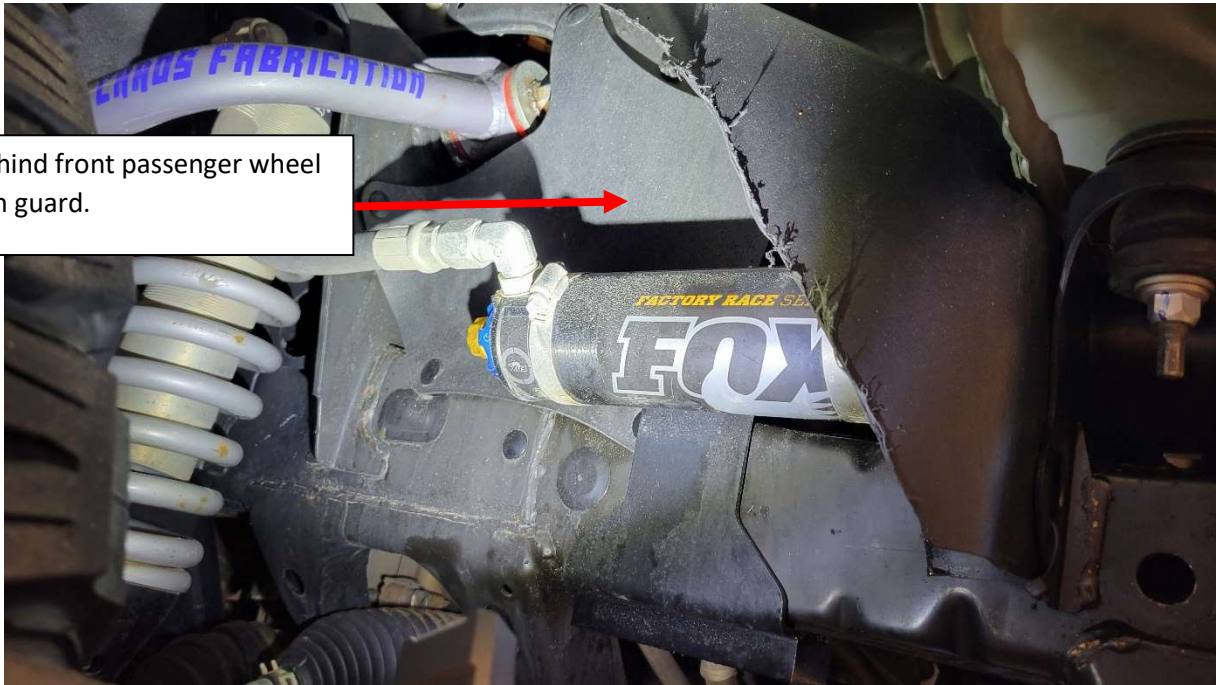

Figure 9: Mount located behind passenger wheel well splash guard.

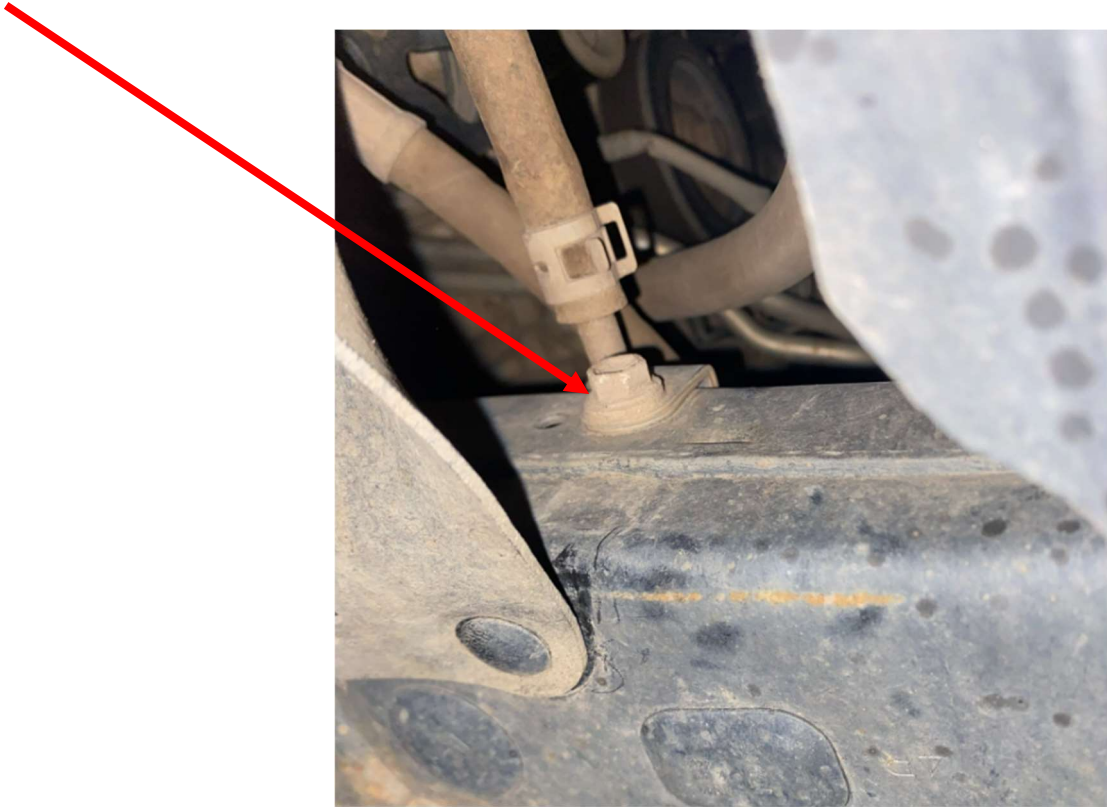

Figure 10: Mount located behind passenger wheel well splash guard.

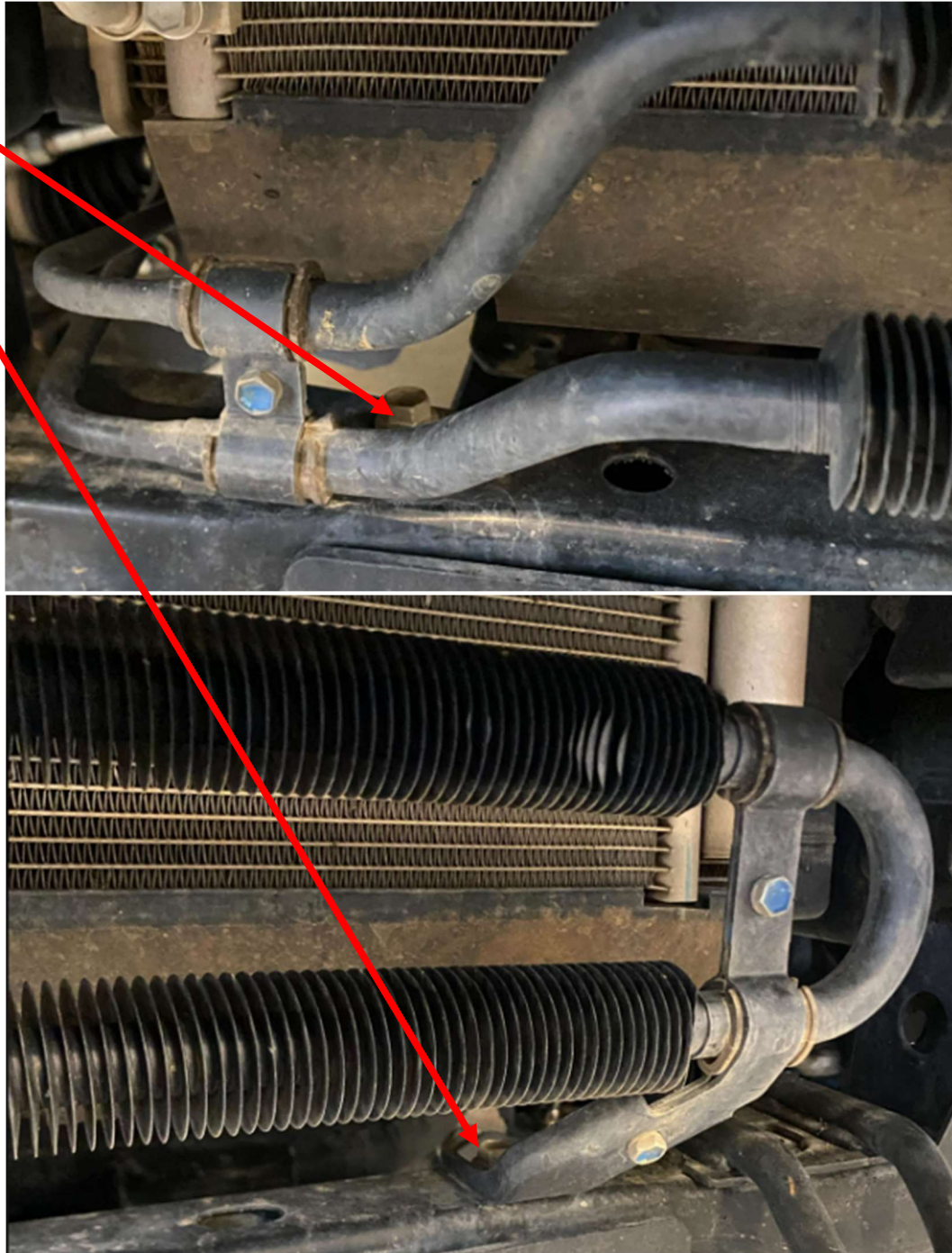

Figure 11: Power steering cooler bolts to remove

- b. Remount the power steering cooler using the provided relocation brackets to space the cooler back roughly 3 inches. Install the brackets as depicted below.

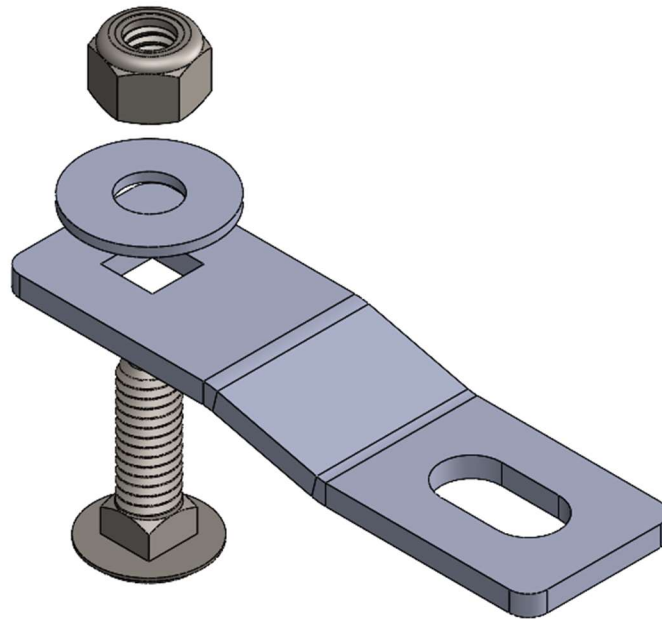

Figure 12: Hardware orientation



Figure 13: Correct installation of frontmost brackets.



Figure 14: Correct installation of frontmost brackets.

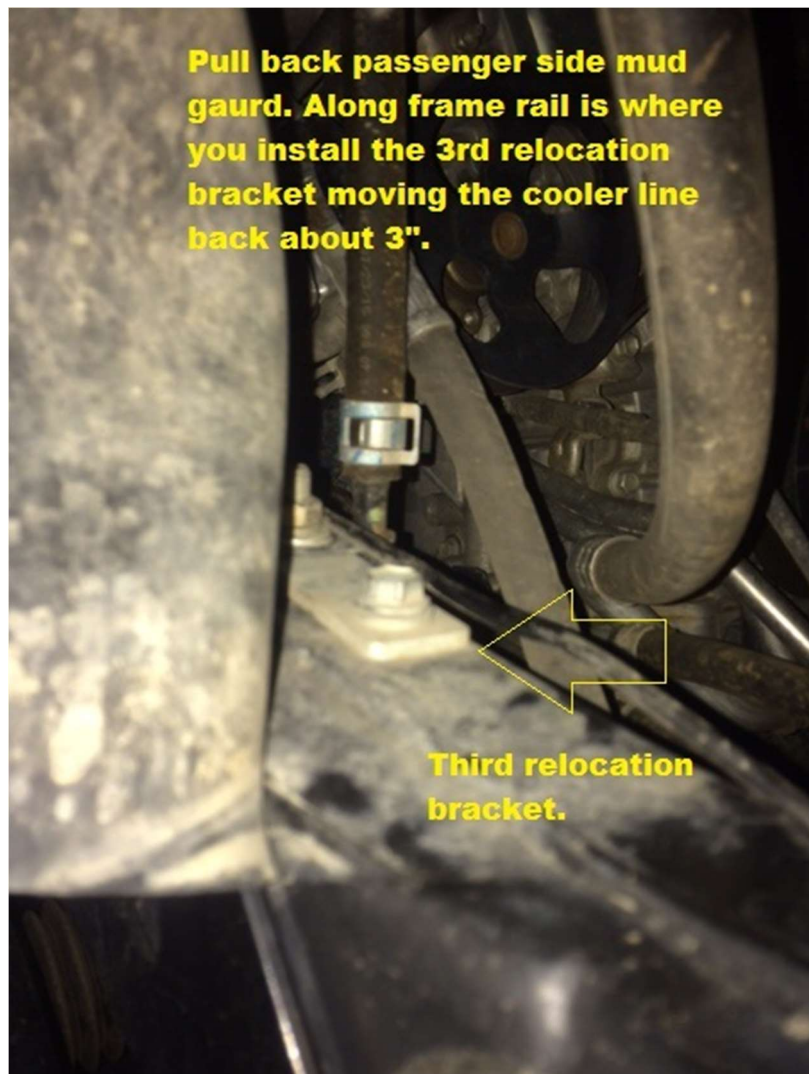

Figure 15: Correct installation of passenger side bracket

- 5) Install the RCI Tacoma Arapaho front bumper on the vehicle to test fitment.
 - a. Align the mounting plate of the RCI bumper with the studs on the mounting face of the vehicle and allow the bumper to rest there.
 - b. Install the set of OEM nuts from the aluminum crash bar to secure the RCI bumper to the vehicle.

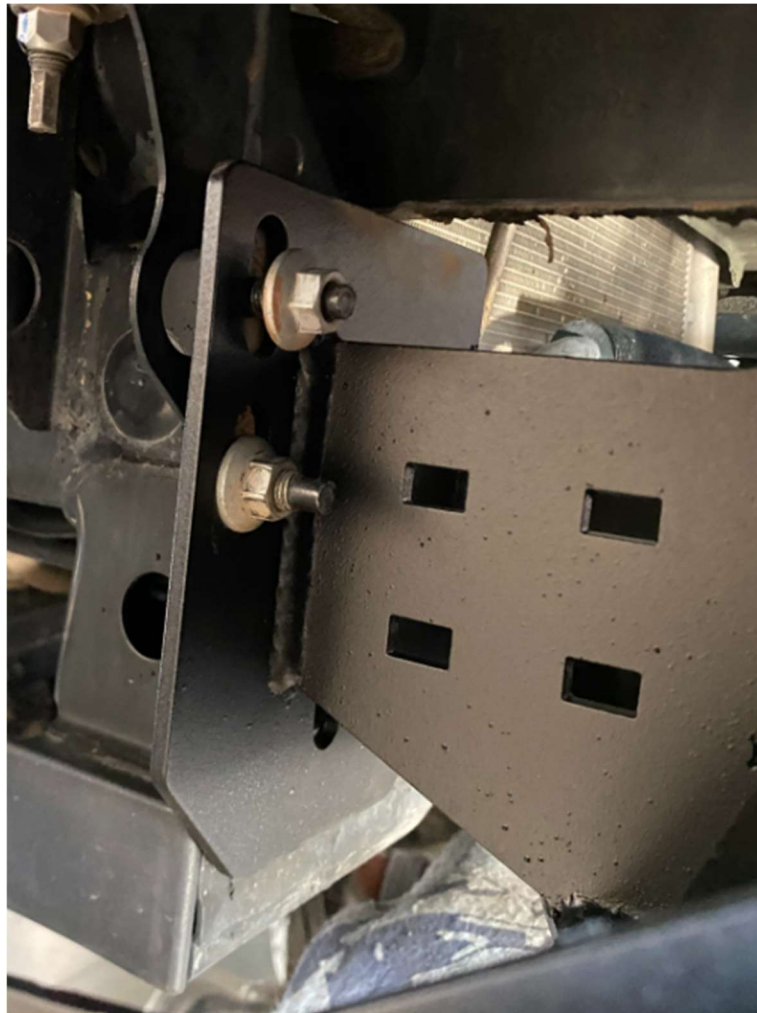

Figure 16: Mounting process of RCI bumper

- c. Align the bumper to desired height and fully tighten all 6 OEM mounting locations.
- d. Inspect the gap between the trimmed OEM bumper and the top plate of the RCI bumper. To verify that the cut was straight and level.
- e. Make adjustments to the OEM bumper as necessary or desired.

- 6) Remove the RCI Tacoma Arapaho front bumper and install any accessories.
 - a. Winches, relocation brackets, light bars, and other accessories should be installed at this time while all areas of the bumper are easily accessible.
- 7) Trim the fender liner as desired.
 - b. We followed the contours of the front of the wheel well.

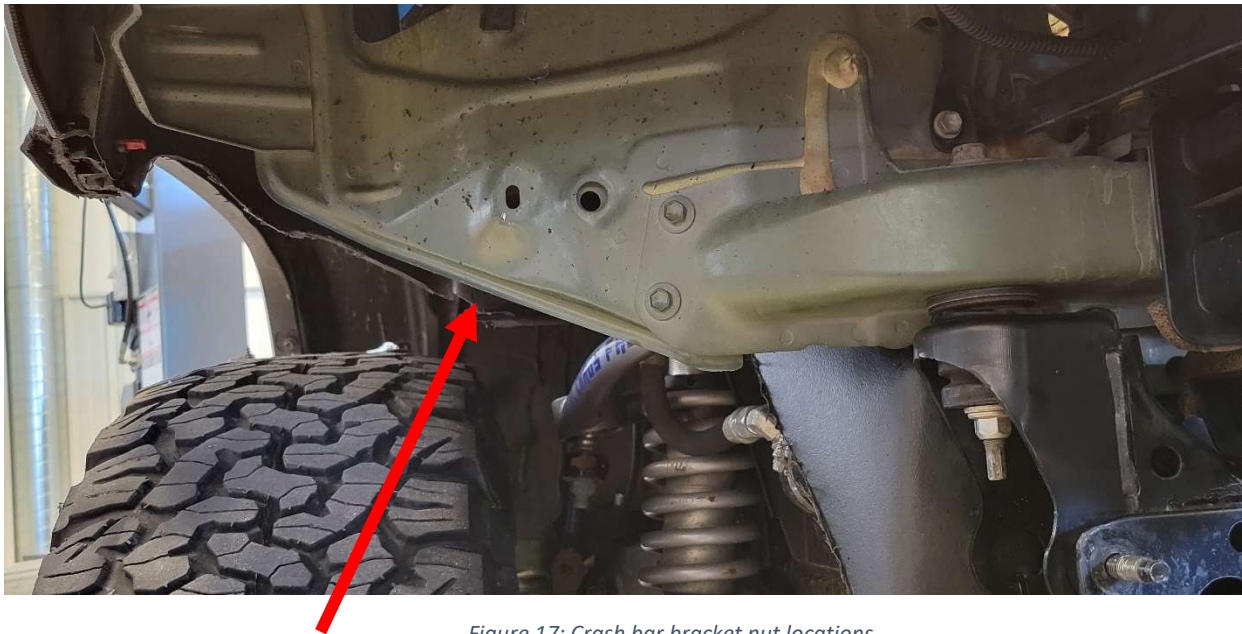

Figure 17: Crash bar bracket nut locations

- 8) Re-install the RCI Tacoma Arapaho front bumper and finalize the installation.
 - a. Align the mounting plate of the RCI bumper with the studs on the mounting face of the vehicle and allow the bumper to rest there.
 - b. Install the set of OEM nuts from the aluminum crash bar to secure the RCI bumper to the vehicle.

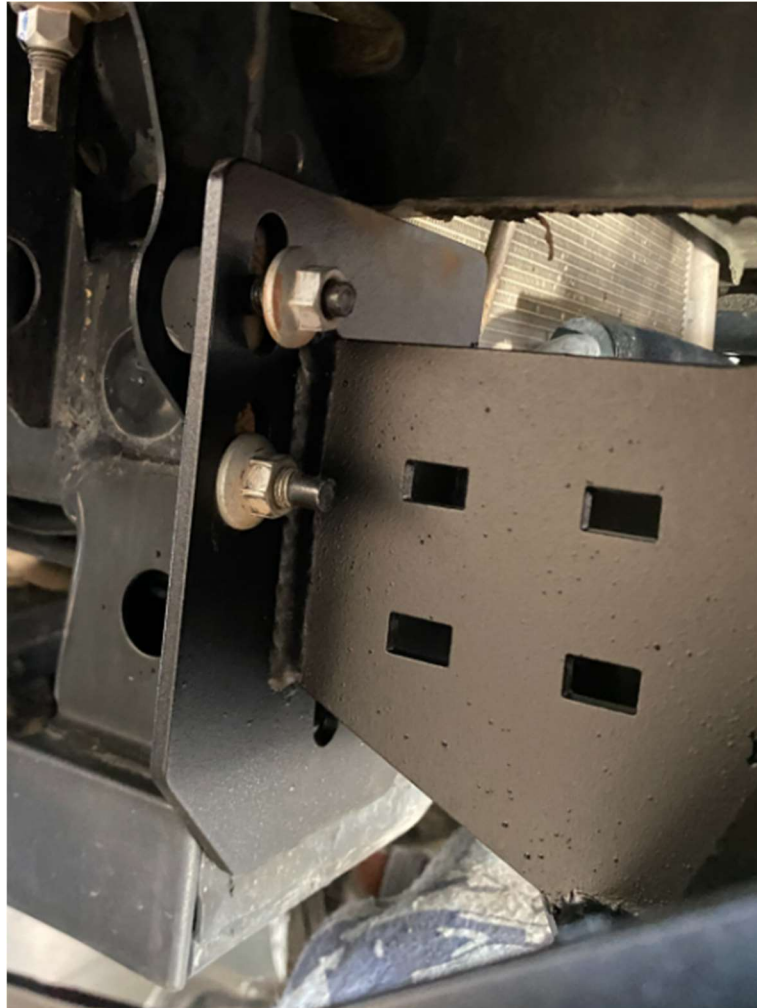

Figure 18: Mounting process of RCI bumper

- c. Align the bumper to desired height and fully tighten all 6 OEM mounting locations.
- d. Collect the provided $\frac{1}{2}$ " x $4 \frac{1}{2}$ " Hex bolts, $\frac{1}{2}$ " Washers, and the $\frac{1}{2}$ " Nylock Nuts.
- e. Install the hardware in the lowest mounting hole as depicted below.

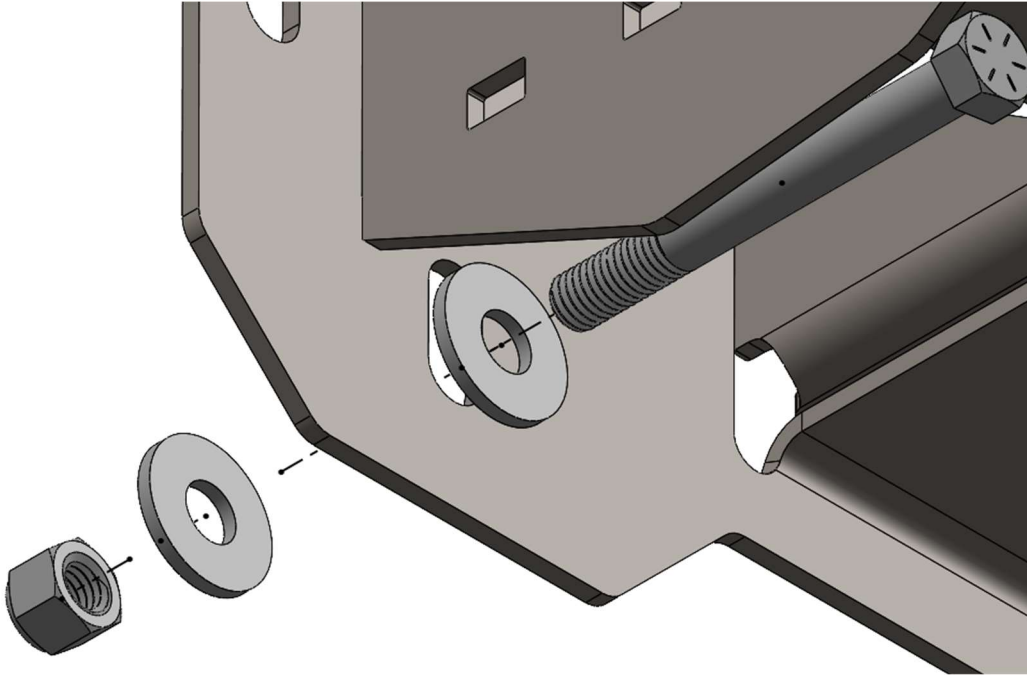

Figure 19: Hardware orientation



Figure 20: Correct installation

- 9) Complete the installation by ensuring all mounting hardware is fully tightened and the bumper is aligned properly.



Enjoy your new RCI protection!



Share your new install with us on social media!

We love seeing our products out in the wild!

www.rcimetalworks.com

sales@rcioffroad.com

970-797-3089

REV: 1 | 9/29/2022



Disclaimer: The products sold by RCI Metalworks are intended for off-road use only, should not be modified, and are for use only on the vehicle(s) specifically stated. RCI Metalworks makes no warranties express or implied, including of fitness for a particular purpose or merchantability. RCI Metalworks will not be liable for any damages arising out of the use or misuse of its products. It is the customers' responsibility to ensure the products are safely and properly attached to the vehicle, and all products should be installed by trained professionals. We strive to maintain extremely high quality standards; however, all RCI Metalworks products are individually handcrafted, may vary slightly, and may contain minor imperfections. Due to the nature of raw aluminum, the material may have minor scratches and other blemishes caused by the manufacturing process, especially on the back side of product. RCI Metalworks is constantly seeking to improve its products and reserves the right to make changes to any product.