

RCI 15+ F-150 Differential Skid Plate (9.75) Install Guide

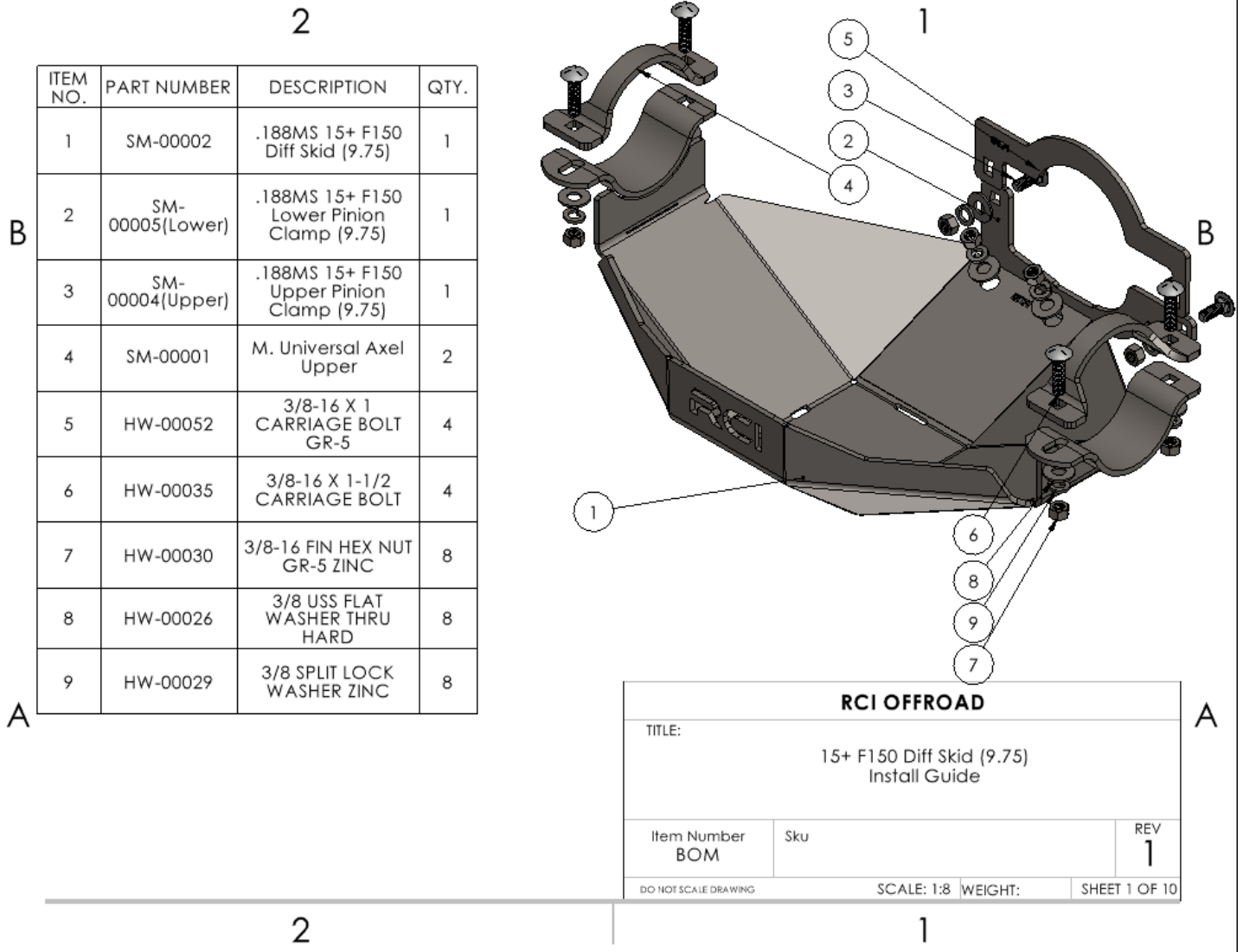

Figure 1: BOM

INSTALLATION STEPS:

****Use hand tools, impact wrenches may cause damage if over torqued****

- 1) Begin by unpacking and removing all components and hardware. Please verify that all hardware and mounting components are present. Reference your original order invoice and verify all items are accounted for.
- 2) Loosely install the Lower Pinion Clamp Bracket to the Rear Differential Skid Plate, using two (2) of each of the included 3/8"x1" Carriage Bolts, 3/8" Split Washers, 3/8" Flat Washer, and 3/8" Nut.
 - a. Install the Lower Pinion Clamp Bracket on the outer face of the Rear Differential Skid Plate as shown:

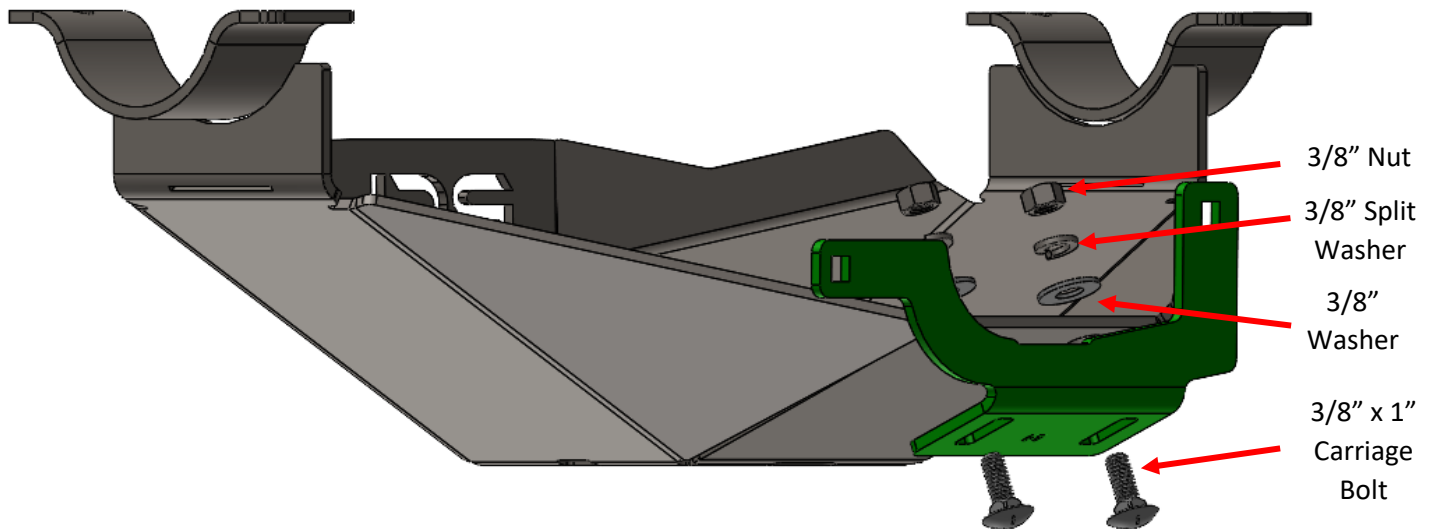

Figure 2: Lower Pinion Clamp Installation

- 3) Lift the Differential Skid assembly up to the rear axle of the vehicle as shown below.

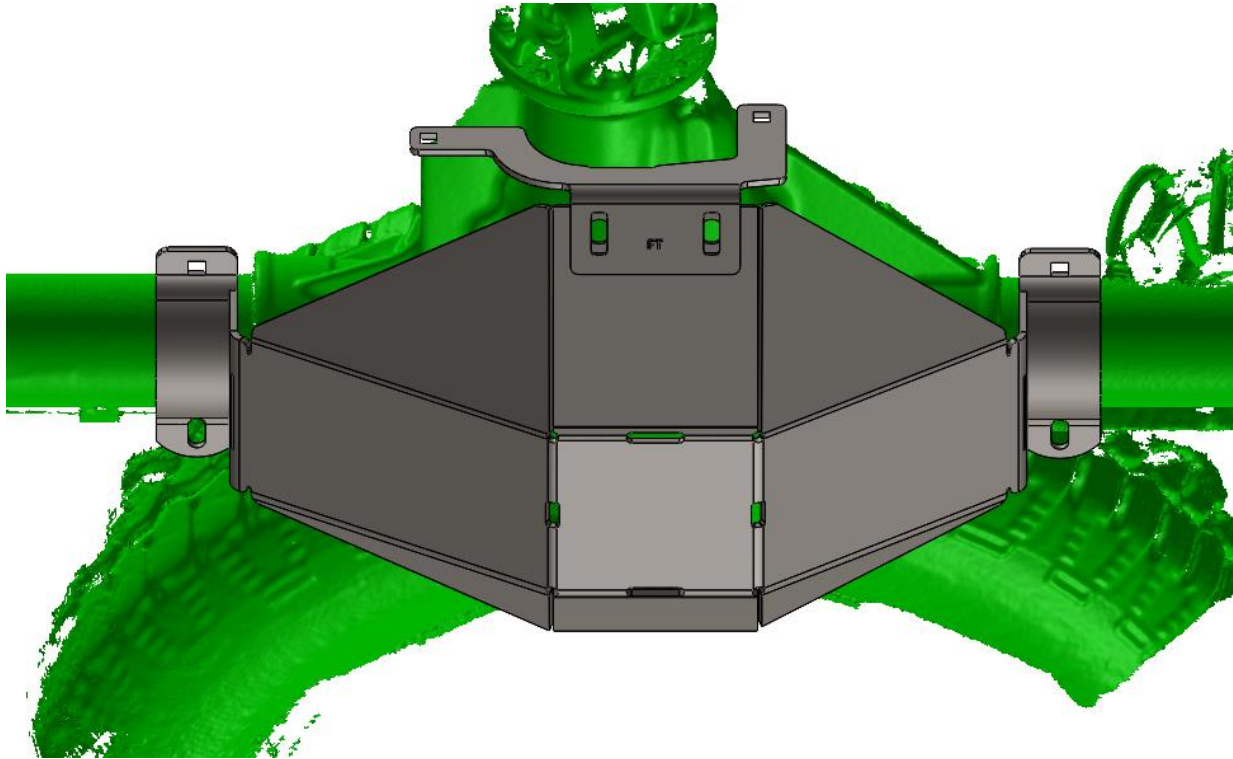

Figure 3: Diff Skid Alignment

- 4) Install the Upper Pinion Clamp with the use of two (2) of each of the included 3/8"x1" Carriage Bolts, 3/8" Flat Washer, 3/8" Split Washer, and 3/8" Nut.
 - a. The Upper Pinion Clamp should be installed over top of the front of the differential housing as shown:

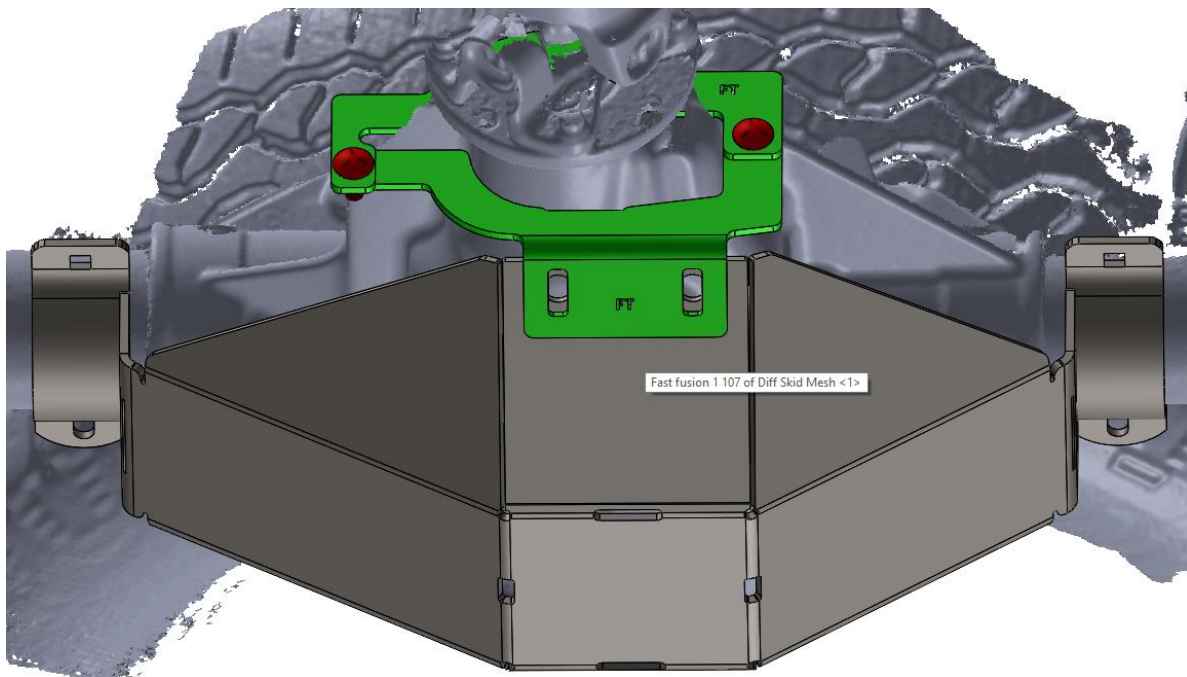

Figure 4: Upper Pinion Clamp Installation

5) Install the hardware in the orientation depicted below.

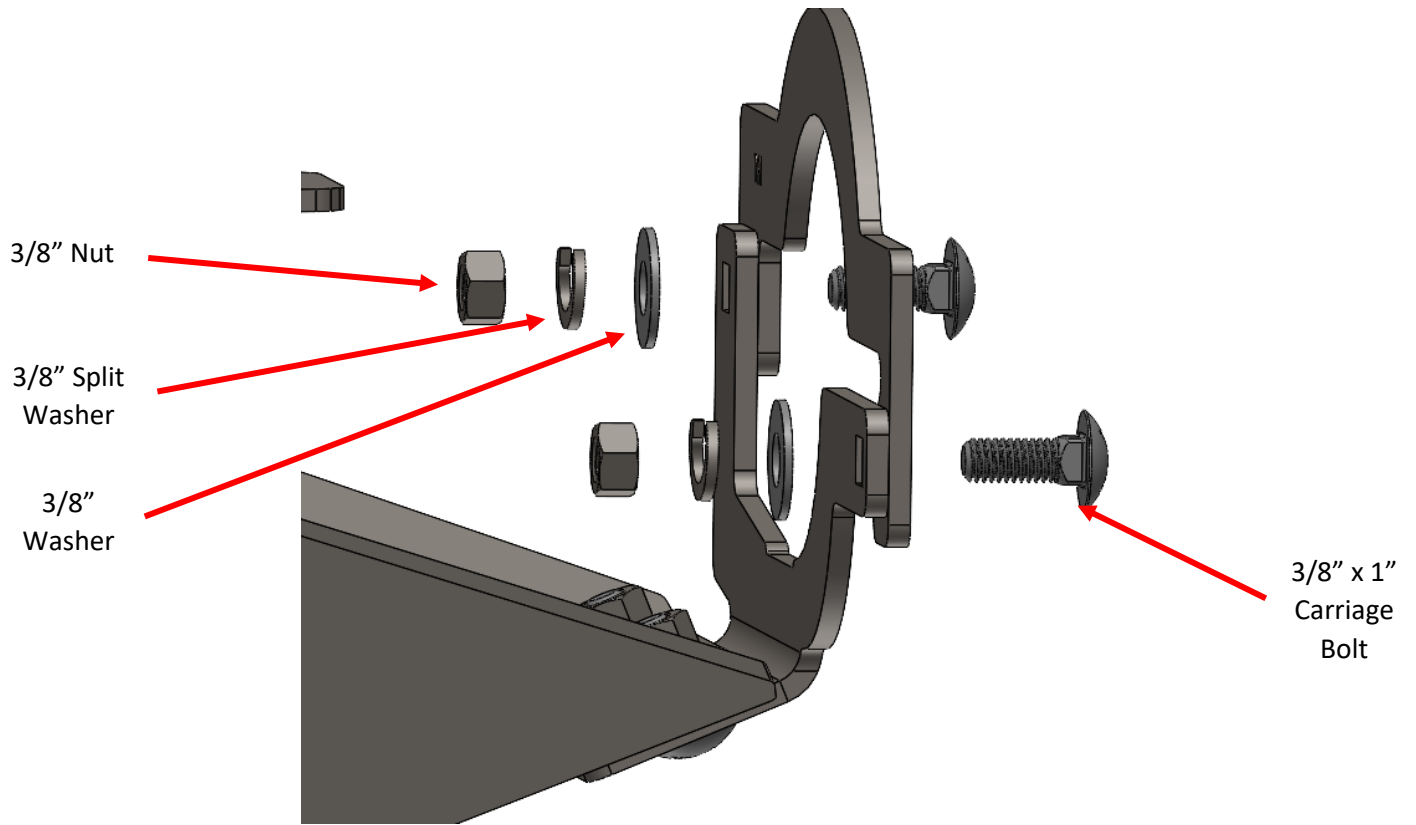

Figure 5: Pinion Clamp Hardware



Figure 6: Pinion Clamp Installation

- 6) Install the Upper Axle Clamps over top of the rear axle with the use of four (4) of each of the included 3/8"x1.5" Carriage Bolts, 3/8" Split Washers, 3/8" Flat Washer, and 3/8" Nut.
 - a. Install hardware with the shown order and orientation.

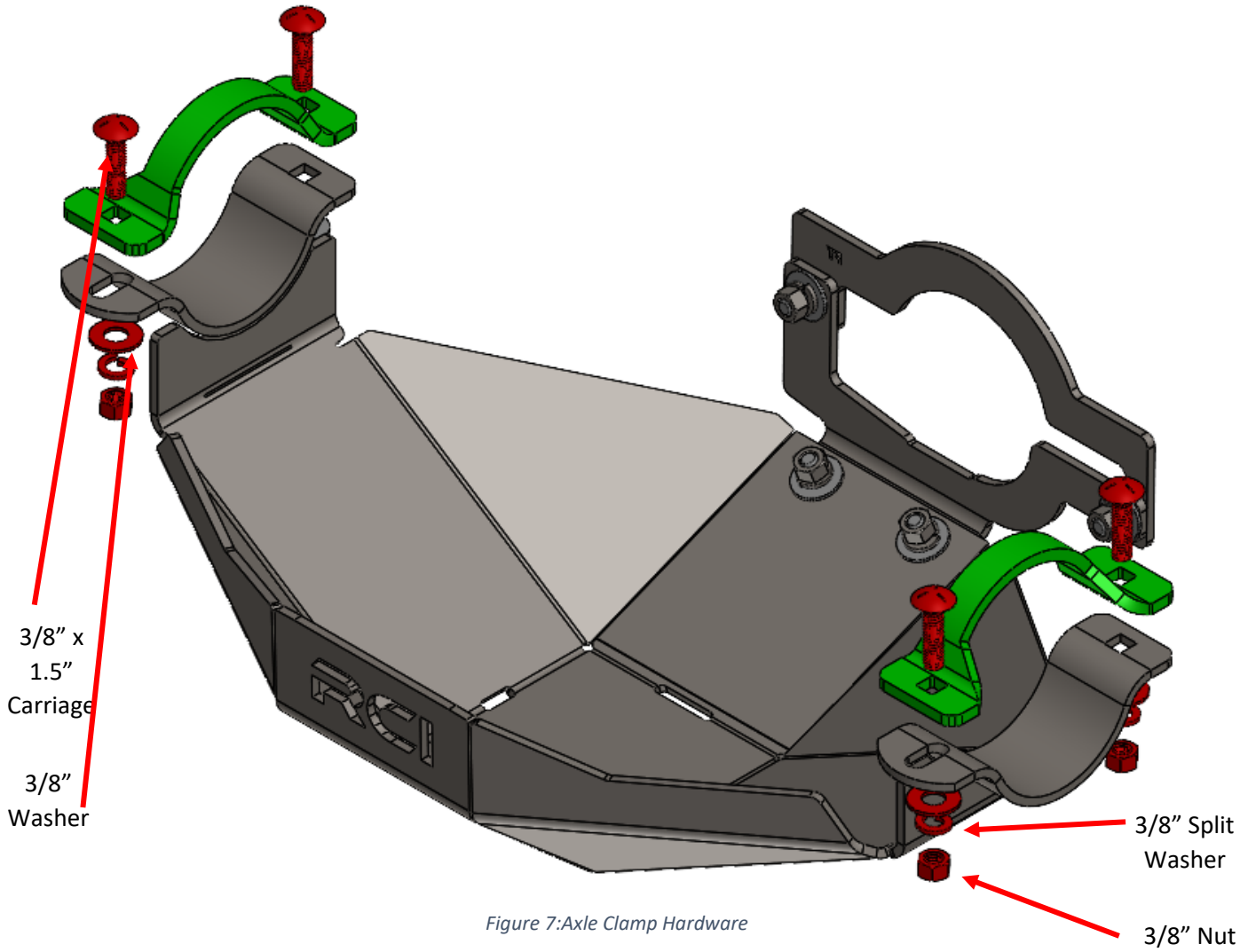

Figure 7: Axle Clamp Hardware



Figure 8: Axle Clamp Installation

Enjoy your new RCI protection!



Share your new install with us on social media!

We love seeing our products out in the wild!

www.rcimetalworks.com

sales@rcioffroad.com

970-797-3089

REV: 1 | 9/29/2022



Disclaimer: The products sold by RCI Metalworks are intended for off-road use only, should not be modified, and are for use only on the vehicle(s) specifically stated. RCI Metalworks makes no warranties express or implied, including of fitness for a particular purpose or merchantability. RCI Metalworks will not be liable for any damages arising out of the use or misuse of its products. It is the customers' responsibility to ensure the products are safely and properly attached to the vehicle, and all products should be installed by trained professionals. We strive to maintain extremely high quality standards; however, all RCI Metalworks products are individually handcrafted, may vary slightly, and may contain minor imperfections. Due to the nature of raw aluminum, the material may have minor scratches and other blemishes caused by the manufacturing process, especially on the back side of product. RCI Metalworks is constantly seeking to improve its products and reserves the right to make changes to any product.