

RCI Bronco Catalytic Guard Installation Guide

****This install guide is applicable to our 21+ Bronco Catalytic Guard ONLY****

ITEM NO.	PART NUMBER	DESCRIPTION	QTY.
3	Bronco Catalytic Guard	1 Pair	1
4	5/16" Steel Flat Washer	CatGuard Hardware kit	8
5	5/16"- Nyloc Nut	CatGuard Hardware kit	8
6	5/16 X 1 Carriage Bolt	CatGuard Hardware Kit	8

DETAIL A
SCALE 2 : 7.5

<p><small>UNLESS OTHERWISE SPECIFIED: DIMENSIONS ARE IN INCHES TOLERANCES: FRACTIONAL ±0.010 ANGULAR: BEND ±0.5 TWO PLACE DECIMAL ± 0.015 THREE PLACE DECIMAL ± 0.010</small></p> <p><small>PROPRIETARY AND CONFIDENTIAL THE INFORMATION CONTAINED IN THIS DRAWING IS THE SOLE PROPERTY OF RCI OFFROAD. ANY REPRODUCTION IN PART OR AS A WHOLE WITHOUT THE WRITTEN PERMISSION OF RCI OFFROAD IS PROHIBITED.</small></p>	<table border="1" style="width: 100%; border-collapse: collapse;"> <tr><td>THICKNESS</td><td></td></tr> <tr><td>MATERIAL</td><td></td></tr> <tr><td>FINISH</td><td></td></tr> <tr><td>DO NOT SCALE DRAWING</td><td></td></tr> </table>	THICKNESS		MATERIAL		FINISH		DO NOT SCALE DRAWING		<table border="1" style="width: 100%; border-collapse: collapse;"> <tr><td>NAME</td><td>KL</td><td>DATE</td><td>3/27</td></tr> <tr><td>CHECKED</td><td></td><td></td><td></td></tr> <tr><td>ENG APPR.</td><td></td><td></td><td></td></tr> <tr><td>MFG APPR.</td><td></td><td></td><td></td></tr> <tr><td>FINAL APPR.</td><td></td><td></td><td></td></tr> </table>	NAME	KL	DATE	3/27	CHECKED				ENG APPR.				MFG APPR.				FINAL APPR.				<p style="text-align: center;">RCI OFFROAD</p> <p style="text-align: center;">TITLE: Bronco CatGuard</p> <table border="1" style="width: 100%; border-collapse: collapse;"> <tr> <td style="width: 30%;">Item Number</td> <td style="width: 30%;">Sheet1</td> <td style="width: 30%;">Sku</td> <td style="width: 10%;">REV</td> </tr> <tr> <td></td> <td></td> <td></td> <td style="text-align: center;">1</td> </tr> </table> <p style="text-align: right;">SCALE: 1:7.5WEIGHT: SHEET 1 OF 5</p>	Item Number	Sheet1	Sku	REV				1
THICKNESS																																							
MATERIAL																																							
FINISH																																							
DO NOT SCALE DRAWING																																							
NAME	KL	DATE	3/27																																				
CHECKED																																							
ENG APPR.																																							
MFG APPR.																																							
FINAL APPR.																																							
Item Number	Sheet1	Sku	REV																																				
			1																																				

INSTALLATION STEPS:

****Use hand tools, impact wrenches may cause damage if over torqued.**

- 1) **Begin by unpacking and removing all components and hardware. Please verify that all hardware, components, and mounting components are present. Please reference your original order invoice and verify all items are accounted for.**
 - a. **PLEASE NOTE:** An RCI Ford Bronco Transmission Skid Plate is required for use with this kit, but one is NOT supplied.
 - b. **Check the Bronco Transmission Skid Plate for holes along the side flanges of the skid plate. If the Transmission Skid Plate does not have holes, skip ahead to page 3 for retrofit installation instructions.**

- 2) If an RCI Transmission Skid Plate is currently installed on the vehicle, it will need to be removed prior to beginning the installation. The catalytic guards are designed to be theft proof and prohibit removal while the Transmission skid plate is fully installed.
- 3) Using the included hardware, secure the catalytic guards to the transmission skid plate as shown below:

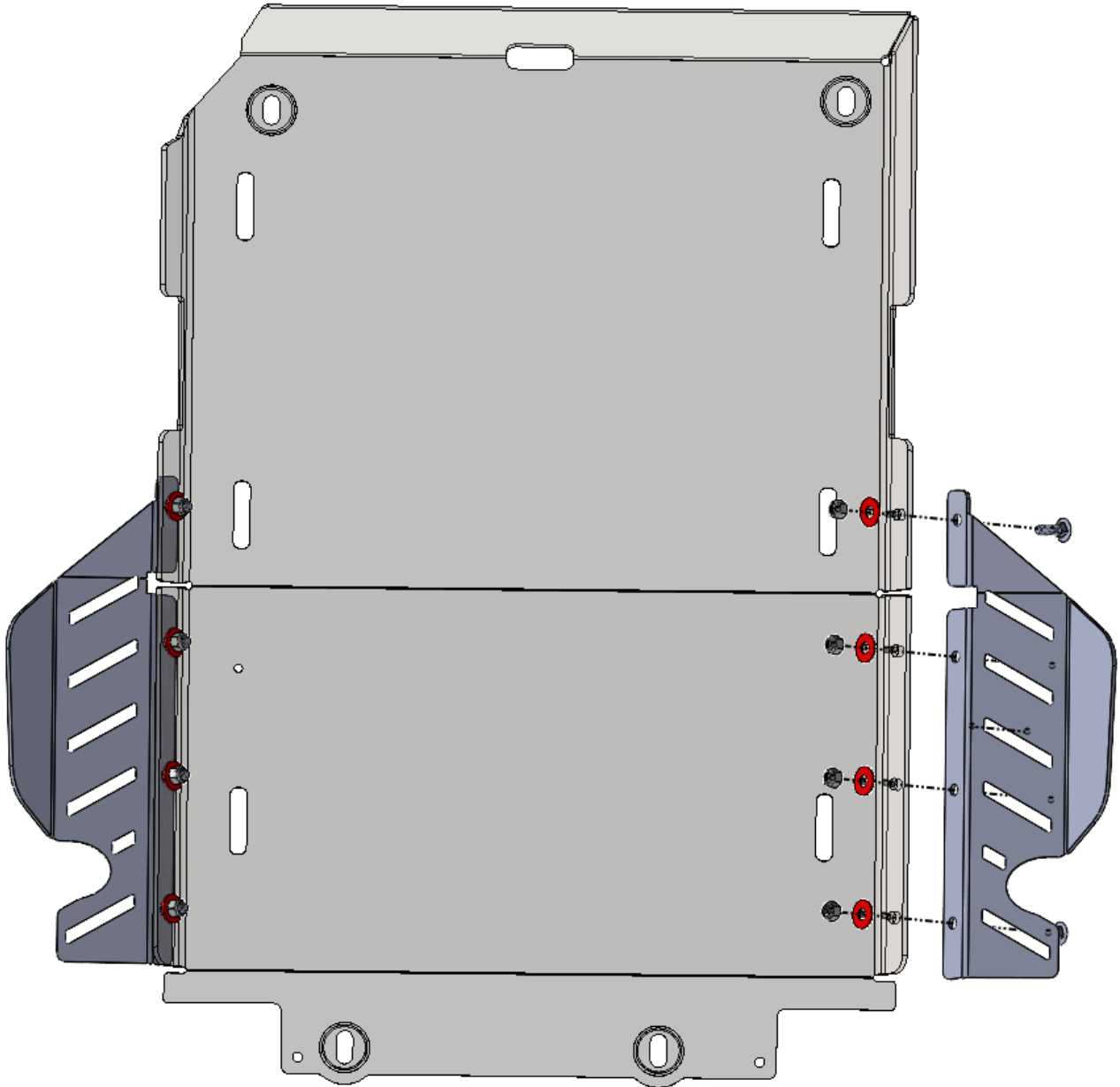

- 4) Follow the steps outlined in the RCI Bronco Transmission Skid Plate install guide to install the transmission skid plate and catalytic guard assembly on the vehicle.

Retrofit of Bronco Transmission Skid Plates Predating Catalytic Guards

- 1) With the transmission skid plate removed from the vehicle, align the driver side catalytic guard with the outside of the flange present on the driver side of the transmission skid plate and clamp it in place.

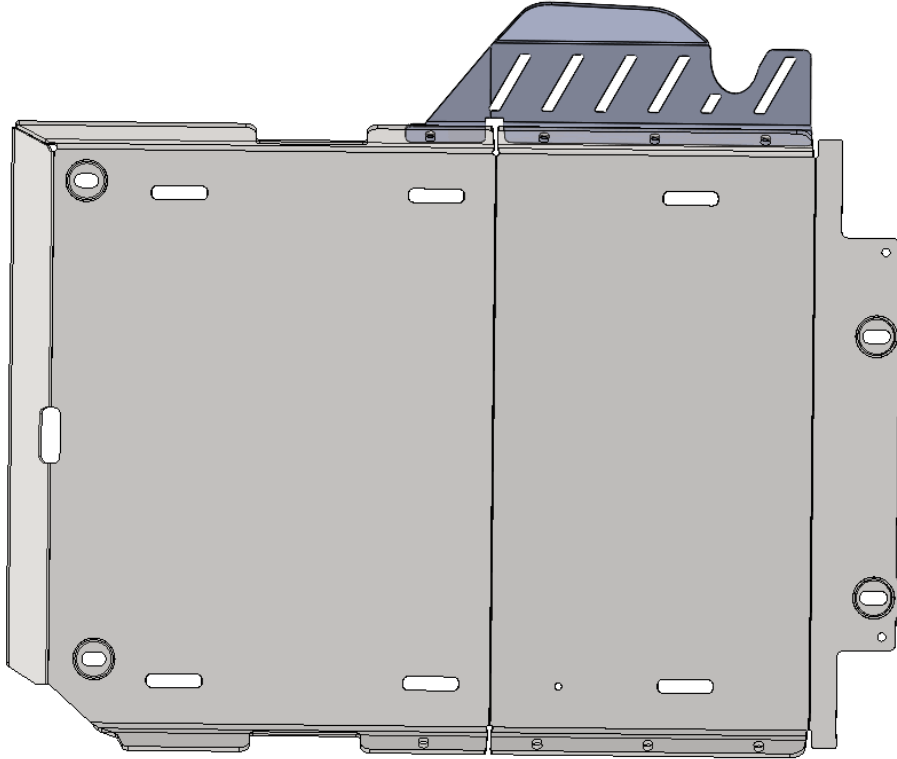

- a. Align front flanges:

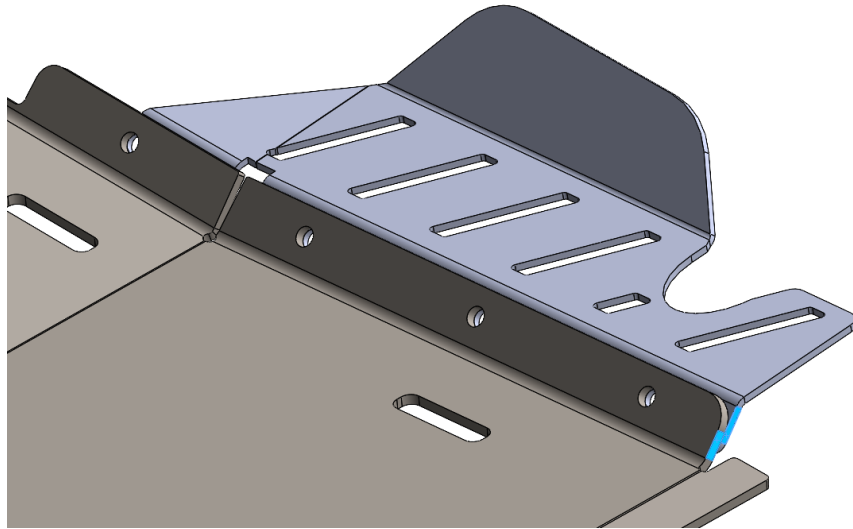

b. Align top flanges:

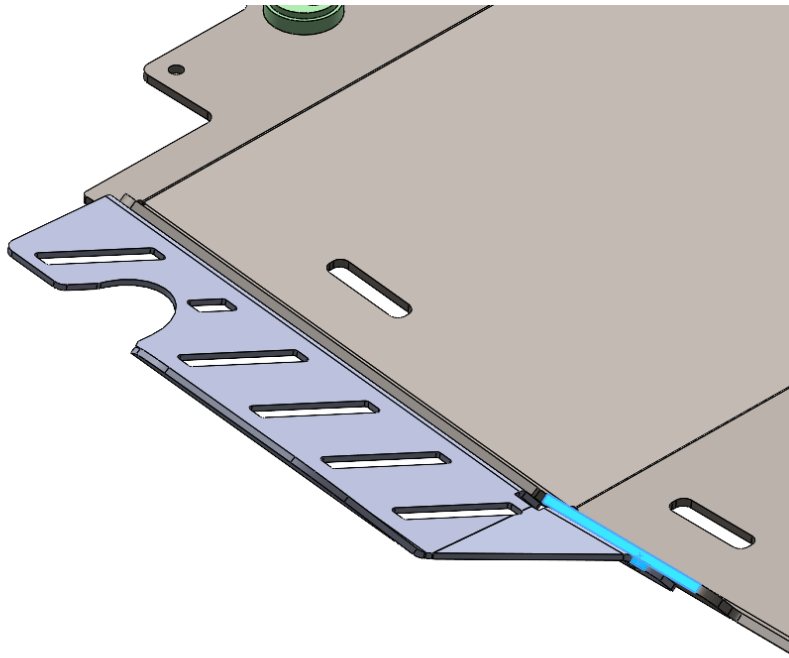

- 2) With the catalytic guard properly aligned with the skid plate, mark the center point of each square cutout using a permanent marker.**
- 3) Remove the catalytic guard and confirm that the marked points are 1/2" from the top of the flange:**

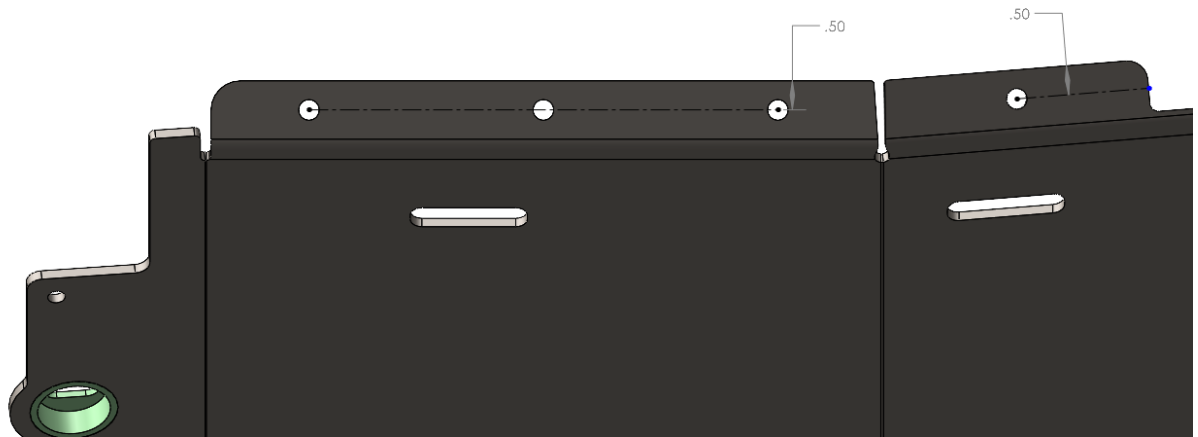

- 4) Use a center punch to indent the permanent marker points at all four mounting locations.
- 5) Use a 1/8" drill bit to drill out all four mounting locations.
- 6) With the pilot holes drilled, enlarge the holes with a 3/8" drill bit.
- 7) Once the mounting locations are drilled out, install the driver side catalytic guard with the included hardware.
- 8) Repeat steps 1-7 for the passenger side catalytic guard.
- 9) Follow the Bronco transmission skid plate install guide to install the transmission skid plate and catalytic guard assembly on the vehicle.

Share your new install with us on social media!

We love seeing our products out in the wild!



Enjoy the new catalytic guards!!!

Disclaimer: The products sold by RCI Metalworks are intended for off-road use only, should not be modified, and are for use only on the vehicle(s) specifically stated. RCI Metalworks makes no warranties express or implied, including of fitness for a particular purpose or merchantability. RCI Metalworks will not be liable for any damages arising out of the use or misuse of its products. It is the customers' responsibility to ensure the products are safely and properly attached to the vehicle, and all products should be installed by trained professionals. We strive to maintain extremely high quality standards; however, all RCI Metalworks products are individually handcrafted, may vary slightly, and may contain minor imperfections. Due to the nature of raw aluminum, the material may have minor scratches and other blemishes caused by the manufacturing process, especially on the back side of product. RCI Metalworks is constantly seeking to improve its products and reserves the right to make changes to any product.