

## RCI 22+ TOYOTA TUNDRA 32-GAL FUEL TANK SKID PLATE INSTALLATION GUIDE

**\*\*This install guide is applicable to our 22+ Toyota Tundra 32Gal Fuel Tank Skid Plate ONLY\*\***

ITEM NO.	PART NUMBER	QTY.
1	.100MS 22+ Tundra 32Gal Fuel Tank Skid Rear	1
2	.100MS 22+ Tundra 32Gal Fuel Tank Skid Front	1
3	.188MS 22+ Tundra 32Gal Fuel Bracket	1
4	M8 Nylock Nut	7
5	5/16" Steel Flat Washer	7
6	M8 x 20mm Bolt	1
7	3/8" x 1" Carriage Bolt	5
8	3/8" Split-Washer	5
9	3/8" Nut	5
10	3/8" Washer	6
11	22+ Tundra Fuel Tank Straps	4 Straps

\*NOTE: Item #11 is only included if selected by customer

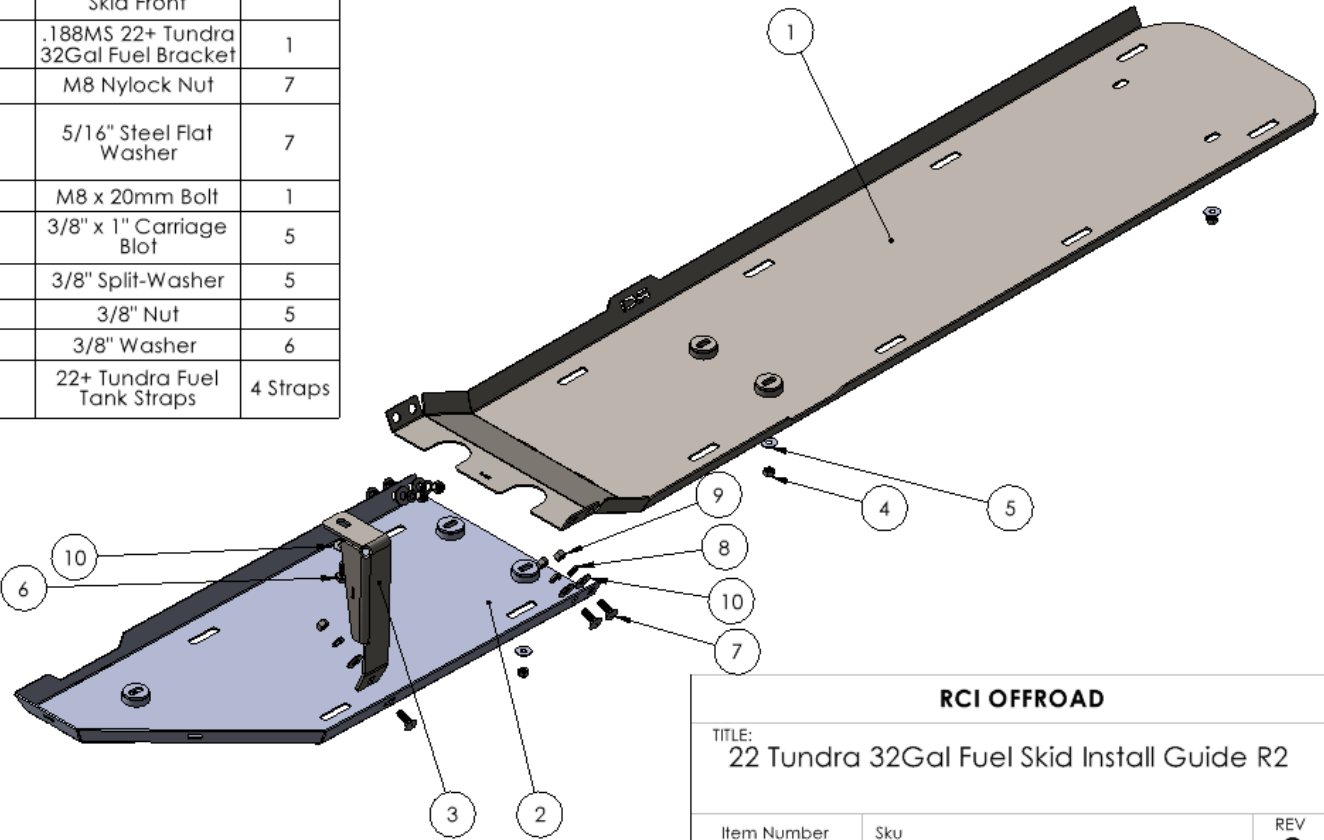

<b>RCI OFFROAD</b>		
TITLE: 22 Tundra 32Gal Fuel Skid Install Guide R2		
Item Number Sheet1	SKU	REV <b>2</b>
SCALE: 1:24 WEIGHT:		SHEET 1 OF 11

Figure 1

### INSTALLATION STEPS:

**\*\*Use hand tools, impact wrenches may cause damage if over torqued.**

- 1. Begin by unpacking and removing all components and hardware. Please verify that all hardware, components, and mounting components are present. Please reference your original order invoice and verify all items are accounted for.**

## INSTALLATION STEPS FOR THE TRD PRO MODEL OR VEHICLES WITH THE TRD OFFROAD PACKAGE:

**\*\* (Models with the factory plastic fuel tank skid plate).**

2. Remove the seven (7) M8 nuts securing the factory plastic fuel tank “skid plate” to the factory fuel tank straps. Remove the factory plastic fuel tank “skid plate”.
3. Collect the longer L-shaped Fuel Tank Bracket, one (1) M8 x 20mm bolt, and one (1) 3/8” Flat Washer.
4. Loosely install the bracket towards the front of the fuel tank in the threaded hole located above the fuel tank on the driver side of the vehicle. Reference Figure 2.

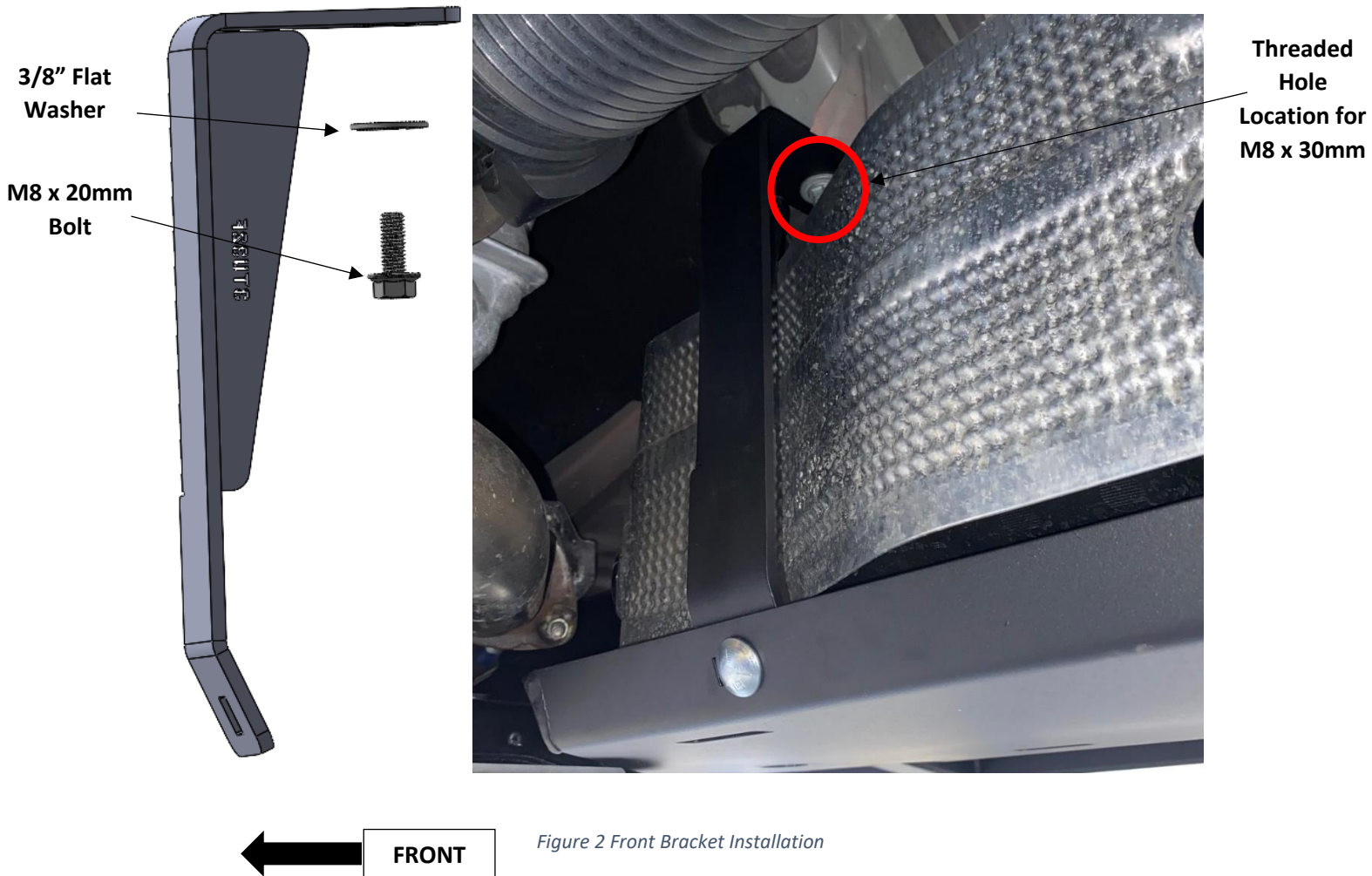
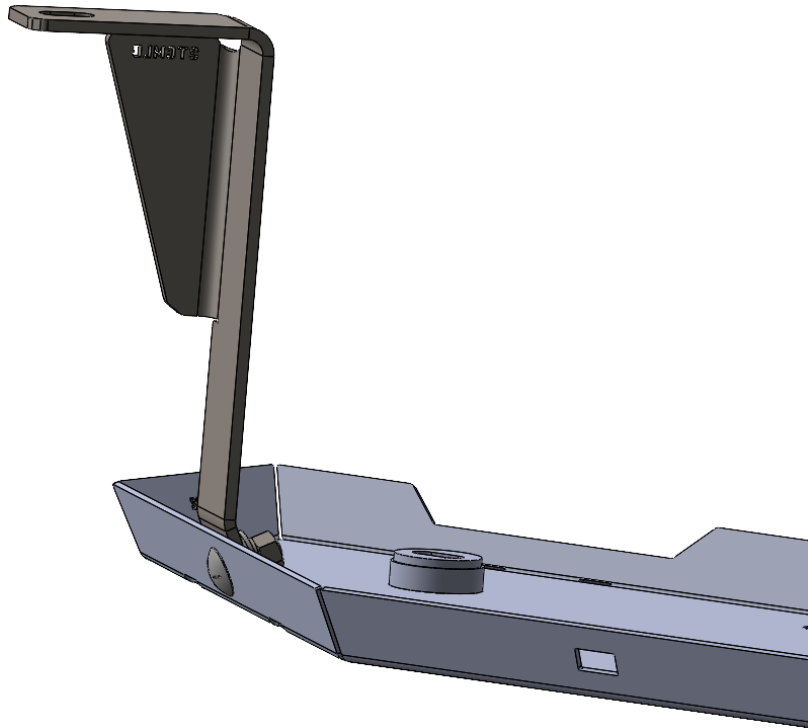

Figure 2 Front Bracket Installation

- a. **NOTE:** For Crewmax 6.5ft bed models, use the included extra bracket for this step (3TCMLB) and install it as depicted below.



*Figure 3 Crewmax Longbed Front Bracket Correct Install*

5. **Lift the rear section of the RCI Fuel Tank Skid Plate up to the rear two (2) factory fuel tank straps. Align the factory fuel tank strap studs with the mounting holes on the RCI Fuel Tank Skid Plate. Loosely secure the Fuel Tank Skid Plate to the factory fuel tank strap studs with either the factory hardware or the included M8 locknuts and 5/16" washers.**

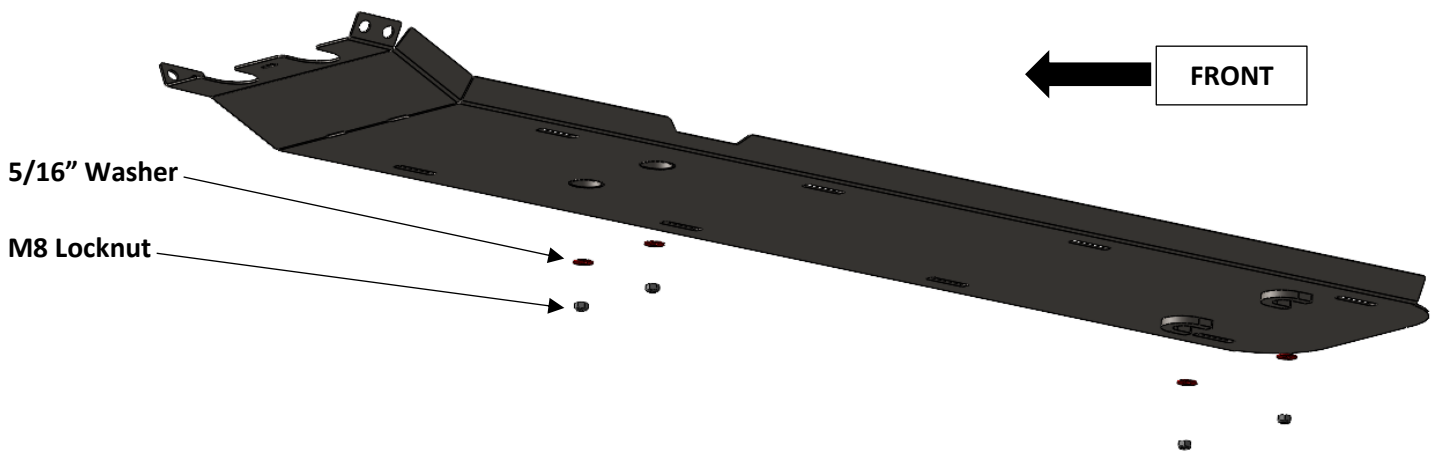

*Figure 4 Rear Section Hardware*

- Lift the front half of the Fuel Tank Skid Plate up to the factory fuel tank straps. Align the skid plate up with the three exposed mounting studs and loosely install three (3) of the provided M8 Locknuts with three (3) 5/16" Washers.



Figure 5 Frontmost Mounting Stud

- With all hardware loosely fastened, use four (4) of the following to secure the front and rear sections of the Fuel Tank Skid Plate together; 3/8" x 1" Carriage Bolt, 3/8" Split Washer, 3/8" Flat Washer, and 3/8" Hex Nut. Fully tighten the four (4) Carriage Bolts.

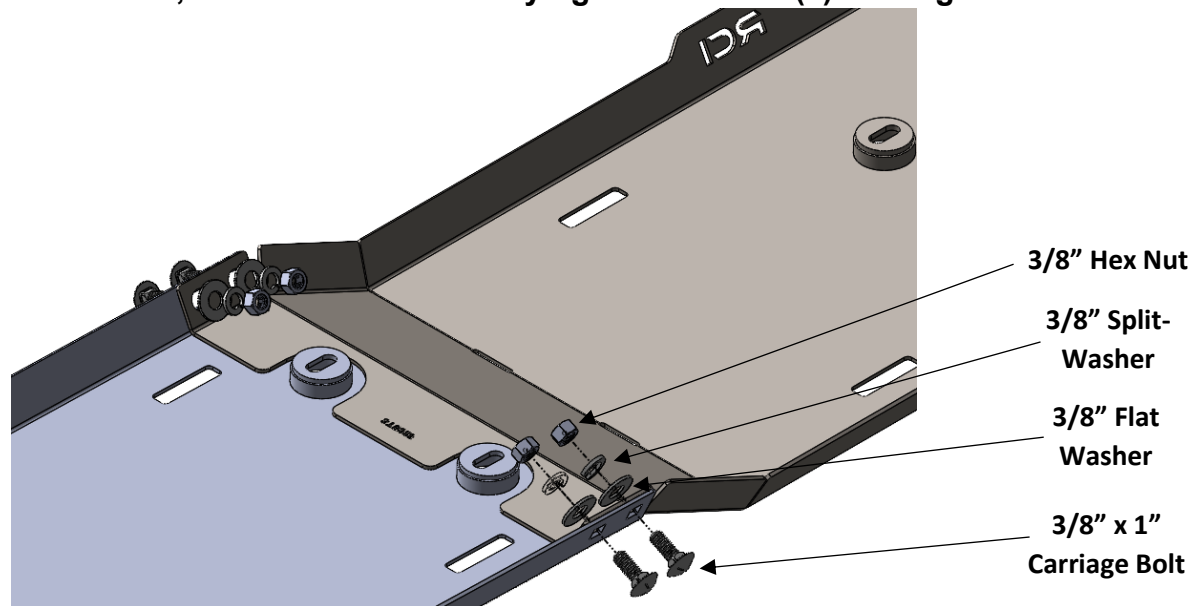
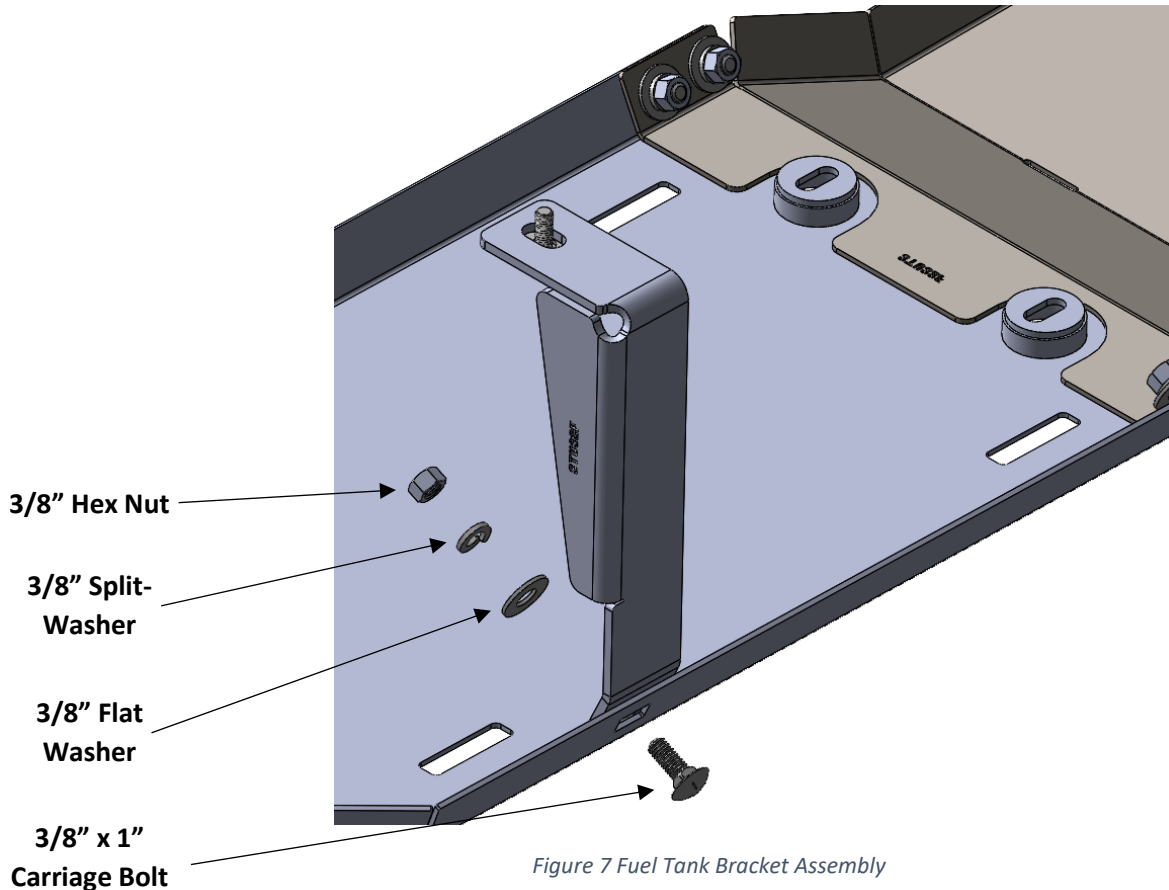

Figure 6 Securing the Front and Rear Skids

- Collect one (1) 3/8" x 1" Carriage Bolt, 3/8" Split Washer, 3/8" Flat Washer, and 3/8" Hex Nut. Use the hardware to attach the larger L-Shaped Fuel Tank Bracket to the front driver side of the skid plate. Be sure the bracket sits inside of the skid plate with the Carriage Bolt threads facing inward. Reference Figure 7.



9. With the RCI Fuel Tank Skid Plate loosely secured, adjust the skid plate so that it is centered with respect to the fuel tank.
10. Tighten all hardware to finish securing the RCI Fuel Tank Skid Plate to the factory fuel tank straps.
  - a. Torque all hardware to match Ford's recommendations.
11. Congratulations! Installation of your new RCI 22+ Toyota Tundra 32Gal Fuel Tank Skid Plate is now complete!

## **INSTALLATION STEPS FOR ALL OTHER MODELS WITHOUT THE STUDED FUEL TANK STRAPS:**

**\*\* (Models without the factory plastic fuel tank skid plate).**

12. Secure the fuel tank to the vehicle with the use of several ratchet straps or hold in place with a floor jack.
13. Remove the three bolts securing the fuel tank straps to the vehicle. The three bolts are located on the passenger side of the fuel tank (One bolt per strap).

Rearmost Strap  
Bolt Location

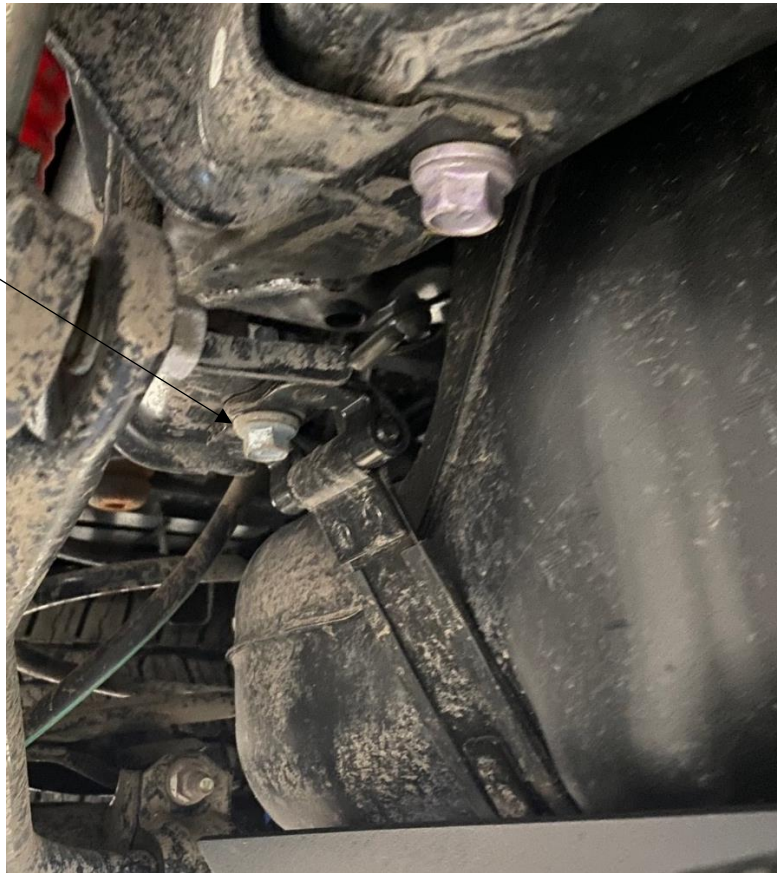

*Figure 8 Example of Strap Mounting Bolt Location*

**14. Swing the fuel tank strap towards the driver side of the vehicle. Remove each pin and retaining pin on the driver side to release the fuel tank strap from the vehicle (three total). Save the removed pins and retaining pins for installing the new straps.**



*Figure 9 Driver Side Pin and Retaining Pin*

- 15. Replace the factory fuel tank straps with the provided (if optional) fuel tank straps with skid plate mounting studs.
  - a. To install the replacement straps, reattach the driver side of the strap on the vehicle mounting point reusing the mounting pin and retaining pin. Swing towards the passenger side of the vehicle towards the fuel tank and reinstall the bolts to secure the straps. Torque the bolts to match Ford's recommendations.
  - b. With the fuel tank successfully secured to the vehicle with the replacement straps, the ratchet straps or floor jack can now be removed.**
  
- 16. After the new studded fuel tank straps are installed, go to Step 2 of the guide to finish installation of the RCI 22+ Toyota Tundra 32Gal Fuel Tank Skid Plate.**

**Enjoy your new RCI protection!**



**Share your new install with us on social media!**

**We love seeing our products out in the wild!**

**www.rcimetalworks.com**

**[sales@rcioffroad.com](mailto:sales@rcioffroad.com)**

**970-797-3089**

REV: 1 | 9/29/2022



---

Disclaimer: The products sold by RCI Metalworks are intended for off –road use only, should not be modified, and are for use only on the vehicle(s) specifically stated. RCI Metalworks makes no warranties express or implied, including of fitness for a particular purpose or merchantability. RCI Metalworks will not be liable for any damages arising out of the use or misuse of its products. It is the customers' responsibility to ensure the products are safely and properly attached to the vehicle, and all products should be installed by trained professionals. We strive to maintain extremely high-quality standards; however, all RCI Metalworks products are individually handcrafted, may vary slightly, and may contain minor imperfections. Due to the nature of raw aluminum, the material may have minor scratches and other blemishes caused by the manufacturing process, especially on the back side of product. RCI Metalworks is constantly seeking to improve its products and reserves the right to make changes to any product.