

RCI 21+ FORD BRONCO 4 DOOR ROCK SLIDER INSTALLATION GUIDE

**** This install guide is applicable to 4 door Bronco vehicle configurations****

2
1

ITEM NO.	PART NUMBER	QTY.
1	21+ Bronco 4 door Slider Driver & Passenger(20° or 5°)	2
2	Carriage Bolt Plate	4
3	7/16" X 5.0" Carriage Bolt	6
4	1/2" Washer (For use with M12 & 7/16" Bolts)	8
5	7/16" Split Lock Washer	6
6	7/16" Hex Nut	6
7	Bronco Speed Clip Bracket	2
8	M8 x 1.25 Speed Clip	6
9	M8 x 1.25 x 30mm Bolt	6
10	5/16" Washer	6
11	M12 x 1.75 x 40mm Bolt	4
12	2" OD Washer	2

DETAIL D
SCALE 1 : 4

DETAIL C
SCALE 1 : 4

DETAIL B
SCALE 1 : 4

DETAIL A
SCALE 1 : 4

A

RCI OFFROAD

TITLE:
21+ Bronco 4 door Slider Install Guide

Item Number Sheet1	Sku	REV 4
SCALE: 1:48 WEIGHT:		SHEET 1 OF 1

A

2
1

- 1) **PLEASE NOTE:** Very few early model 21+ Ford Broncos did not come with holes in the frame that are needed for this installation. Please reference the figure below to ensure your Bronco has the required mounting locations. If your Bronco does not have the depicted mounting locations, please reference **Appendix A** before continuing with the installation.



Holes located
behind the front
tires on the lower
side of the frame

Figure 1

- 2) Begin by unpacking and removing all components and hardware. Please verify that all hardware, components, and mounting components are present. Reference your original order invoice and verify all items are accounted for.
- PLEASE NOTE:** Sliders purchased with an RCI Black Powder Coat should be inspected thoroughly for any possible damage during shipment. Once the sliders have been mounted to the vehicle, RCI will no longer be able to assist with powder coat damage that may have occurred in transit.
 - Sliders purchased in Bare Metal should be cleaned with Acetone and covered in a rust preventative (powder coat, paint, bed liner, etc.) before mounting to the vehicle.
- 3) Start by removing all OEM rock rails or side steps from the truck.
- Disconnect all plastic clips that are holding wiring harnesses or brake lines to the frame

Arrows show which clips need to be disconnected before install



Figure 2

All wiring harness clips

- 4) Collect the two (2) Bronco Speed Clip Brackets (#7) and install the six (6) M8 x 1.25 Speed Clips (#8) as shown in *Figure 3*.

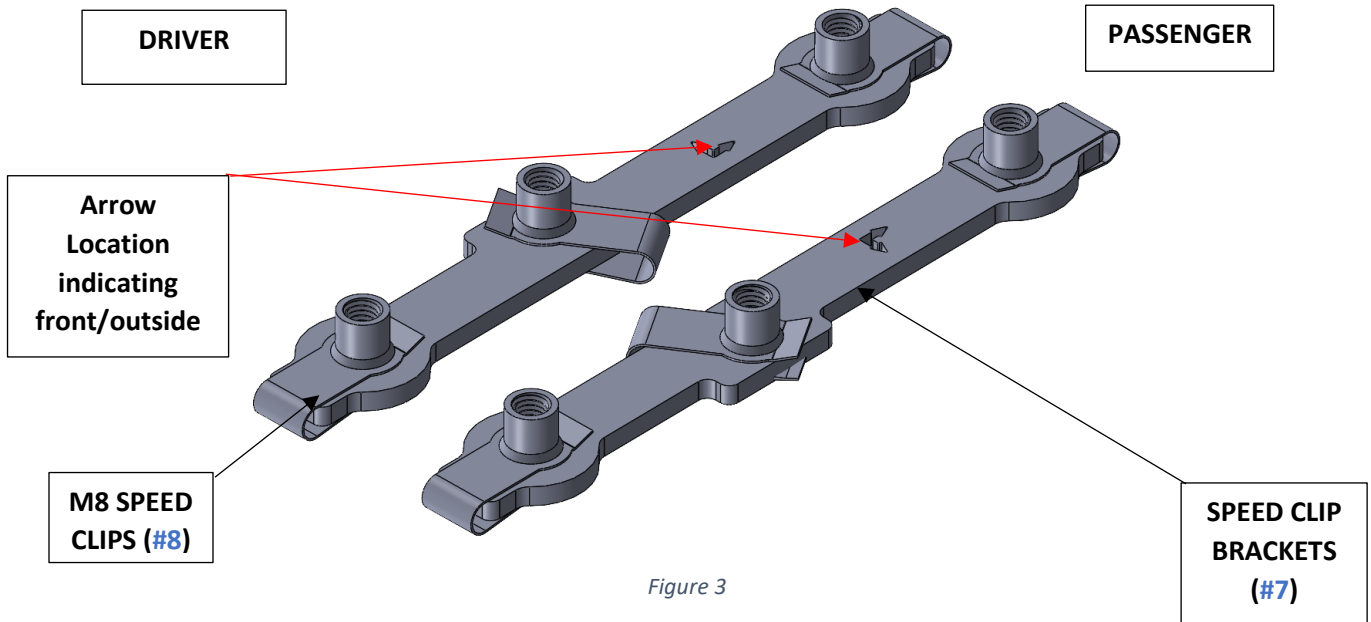

Figure 3

- 5) On the Passenger side behind the front tires on the lower side of the frame there is a slot where the speed clip bracket needs to be installed through. They need to be inserted in the same orientation as shown in *Figure 3*. The locating arrow will be pointing towards the front and the outside of the vehicle. RCI recommends using a small screwdriver to assist in aligning the bracket.



Figure 4

- 6) To help with installation, it's recommended to partially thread one of the M8 x 1.25 x 30mm bolts (#9) with a 5/16" washer (#10) in the center speed clip to help align the outer most speed clips. Once the outer most speed clips are aligned with the holes in the frame, partially thread in two (2) more M8 x 1.25 x 30mm bolts (#9). Fully tighten the center M8 bolt (#9) using a 13mm socket and remove the outermost M8 bolts (#9) so that the threads are visible through the frame and ready for future install use.
- 7) Repeat steps 5 & 6 for the Driver side of the vehicle so that both Bronco speed clip brackets (#8) are installed into the frame and held in place by the center M8 bolts (#9).
- 8) Beginning with the Driver Side Rock Slider (#1). Ensure that there are no OEM or aftermarket bolts in the lower threaded holes on the frame (the provided M12 x40mm bolts (#11) will be installed in these locations).

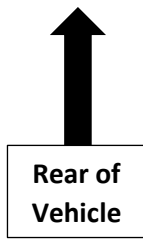

Figure 5

- 9) Once the frame is clear and the speed clip bracket is installed collect two (2) of the M12 x 1.75 x 40mm bolts (#11) with two (2) 1/2" Washers (#4).
- 10) Lift the Driver Side Rock Slider (#1) into position with the smaller frame plate towards the front of the vehicle. Begin threading the two (2) M12 bolts (#11) into the bottom of the frame centering the mounting slots on the frame with the threaded holes. The use of a floor jack, stool, or a helping hand is recommended until fasteners are installed.

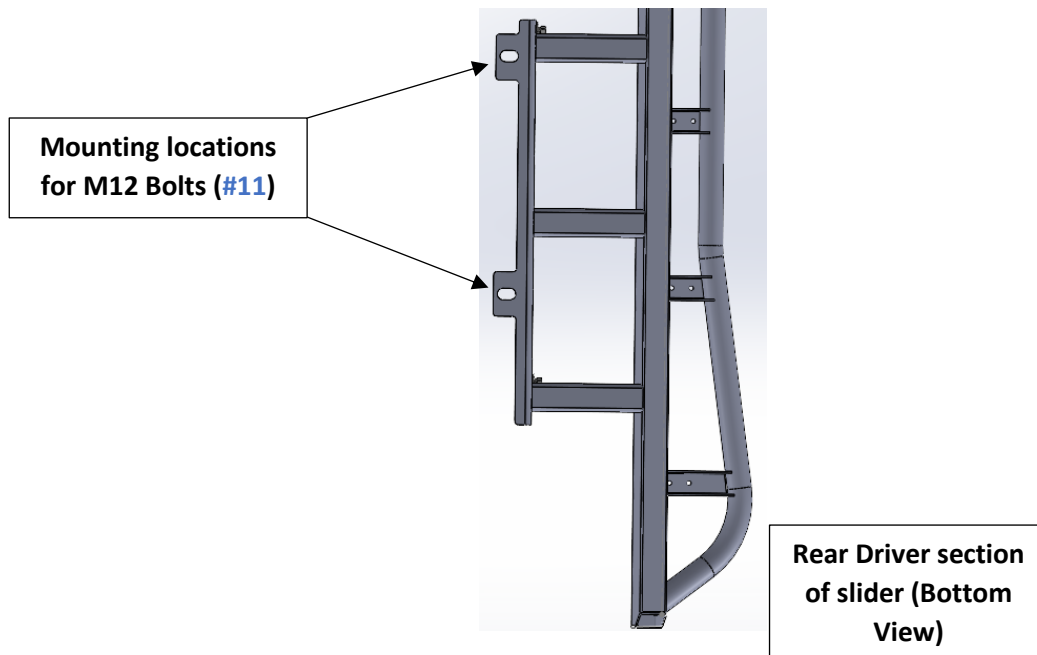

Figure 6

- 11) Loosely tighten both M12 bolts (#11) so that there is slight adjustability in the slider.
- 12) Collect two (2) of the M8 x 30mm bolts (#9) with a 5/16" washer (#10) for each. Adjust the front of the small frame plate so the lower holes are aligned with the threaded speed clip holes. Hand thread the two M8 bolts (#9) with 5/16" washers (#10) until tight.

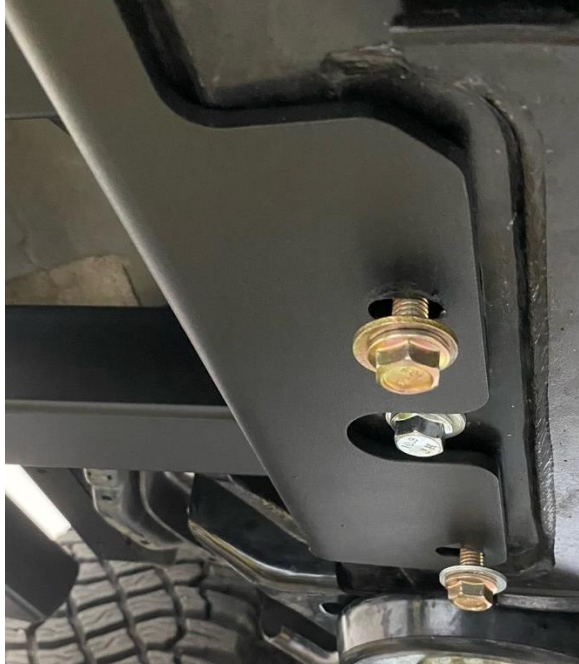

Figure 7

- 13) Once all four (4) lower bolts are threaded (#9 & #11), tighten them down until the slider frame plate is snug to the frame of the truck and then loosen each bolt 1/4 of a turn.
 - a. NOTE: The lower bolts will be fully tightened in step 17.
- 14) Collect two (2) of each: 7/16" x 5" Carriage Bolt (#3), Bronco Carriage Bolt Plate (#2), 1/2" Washer (#4), 7/16" Split Lock Washer (#5), and 7/16" Hex Nut (#6).
 - a. Assemble the two (2) carriage bolts in the order depicted in Figure 8. Thread the 7/16" Hex Nut (#6) down an inch from the bottom of the carriage bolt.

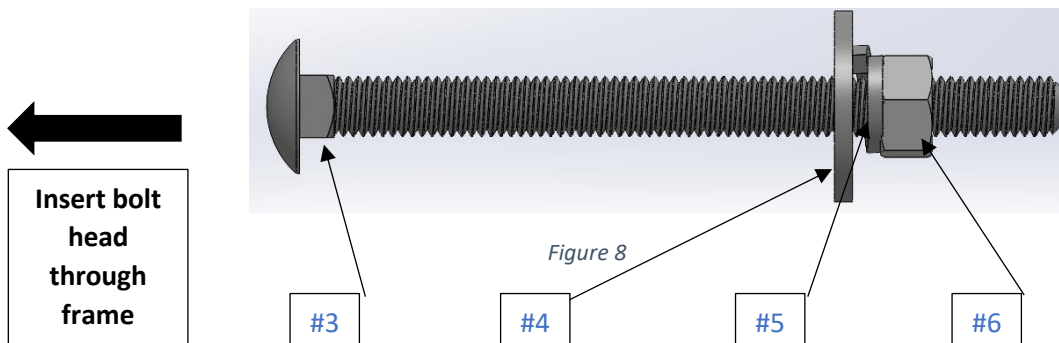
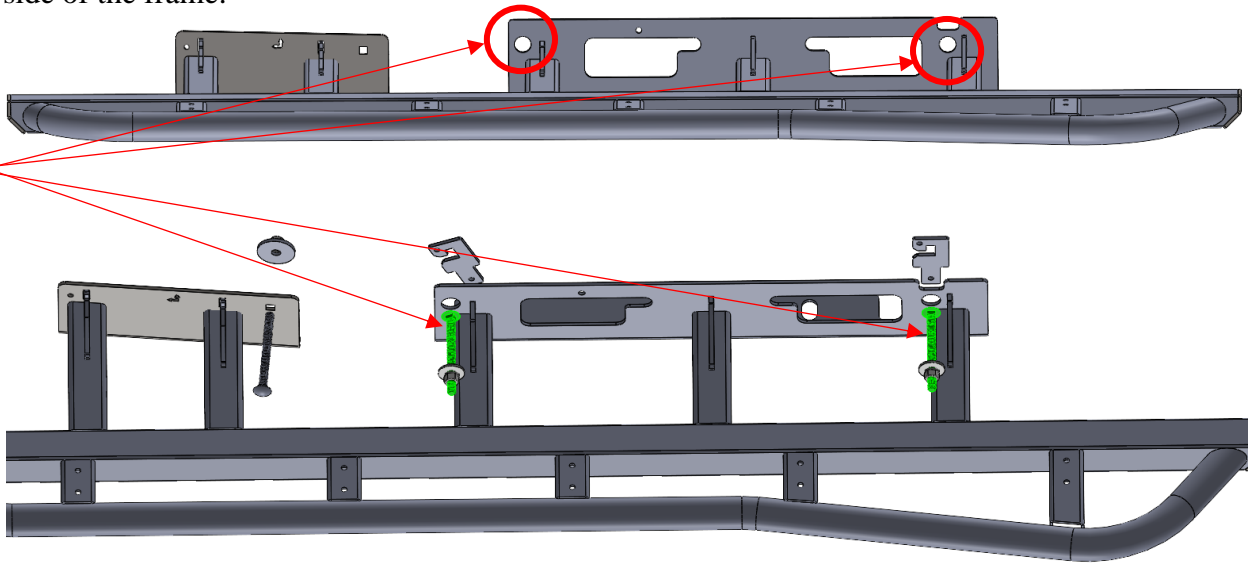

Figure 8

- 15) Feed each carriage bolt through the two (2) 1" holes on the rear slider frame plate with the head of the bolt facing towards the center of the vehicle.
- If needed adjust 7/16" Hex Nut (#6) so that the carriage bolt head is visibly poking out the back side of the frame.

Rear Frame Plate 7/16" x 5" Carriage Bolt Mounting Locations



- 16) Take one of the Bronco Carriage Bolt Plates (#2) and hang it over the square section on the 7/16" carriage bolt (#3). These plates will secure the carriage bolts when tightening the nut to secure the slider frame plate. Hand tighten the 7/16" Hex Nut (#6) until the carriage bolt plate (#2) is snug against the frame. Reference *Figure 9*.

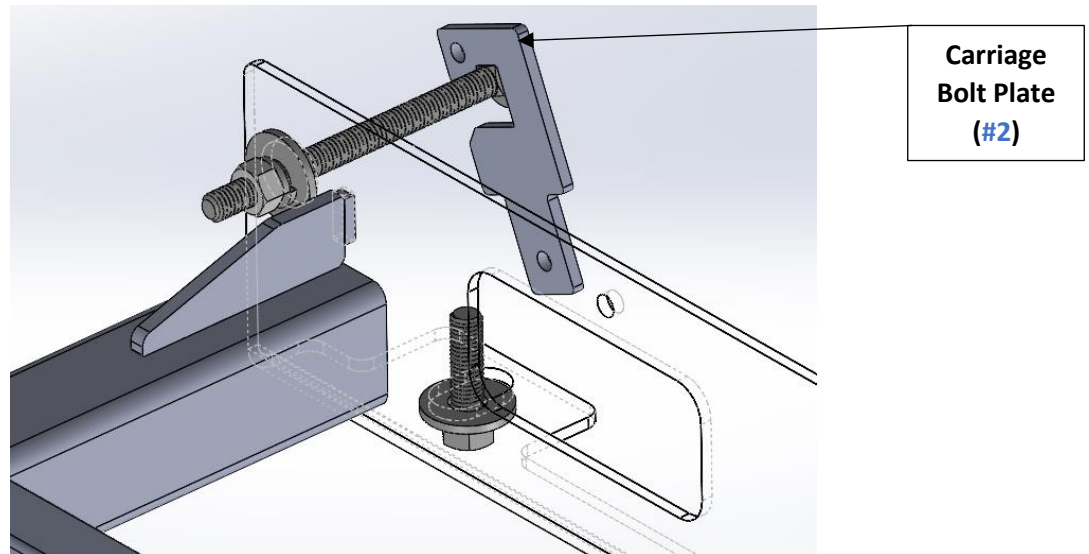
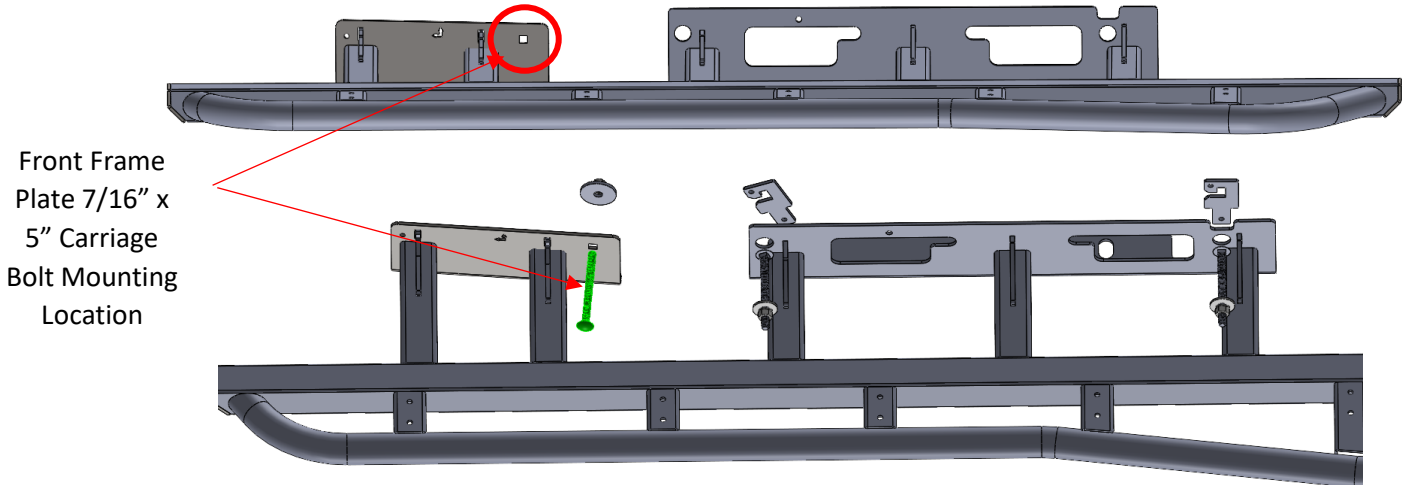

Figure 9

- 17) Repeat Step 15 for the remaining mounting location.
- two (2) total mounting locations on main rearmost frame plate.

18) For the smaller front frame plate collect one of each: 7/16" x 5" Carriage Bolt (#3), Full Moon Washer (#12), 7/16" Split Lock Washer (#5), and 7/16" Hex Nut (#6).



19) Install one (1) 7/16" x 5" Carriage Bolt (#3) with the threads facing the inside of the vehicle through the square mounting hole. On the opposite side of the frame install the 2" OD Washer (#12), 7/16" Split Lock Washer (#5), and 7/16" Hex Nut in that order and hand tighten the nut. Reference *Figure 10*.

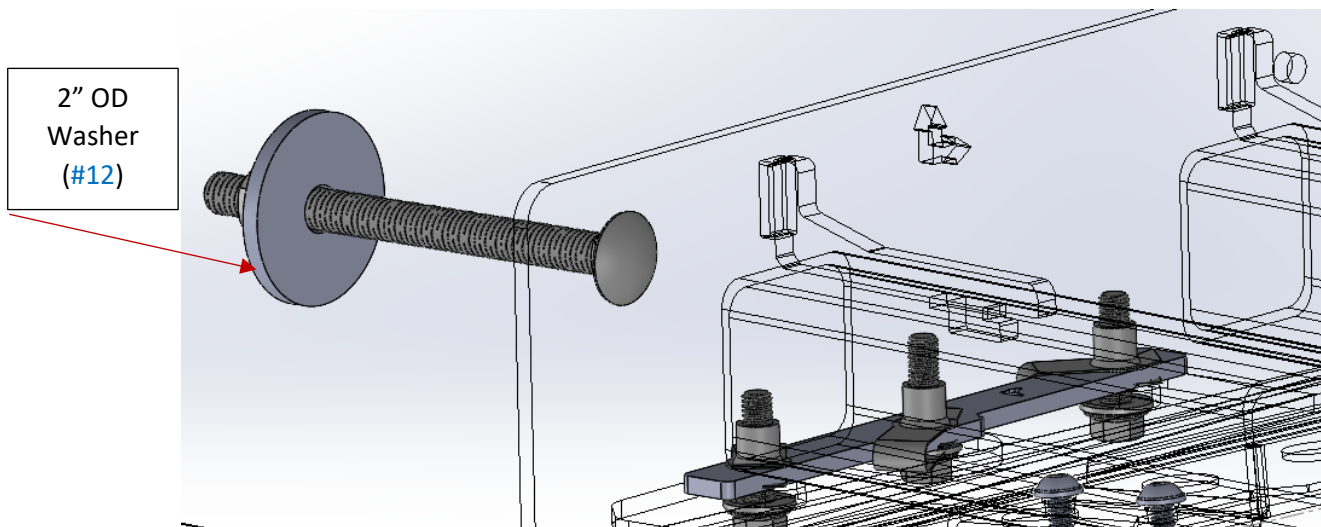

Figure 10 Front Frame Plate

20) Use a 11/16" deep socket to fully tighten the three (3) 7/16" Hex Nuts (#6) until the slider frame plate is flush with the frame of the vehicle. Once the upper mounting locations are tight, re-tighten the four (4) lower mounting locations.

- a. For the driver side of the vehicle, re-install the brake line clips where applicable.

21) The Driver Side Rock Slider is now mounted!

- 22) Prepare the passenger side of the vehicle by removing the two (2) rearmost factory bolts holding the fuel tank skid plate in place.
- PLEASE NOTE:** If your vehicle does not have an OEM fuel tank skid plate, RCI recommends using ratchet straps or a floor jack to secure the fuel tank to the bottom of the vehicle before removing these two (2) supporting bolts.
 - The OEM fuel tank or fuel tank straps will be reinstalled on top of the slider frame plate.

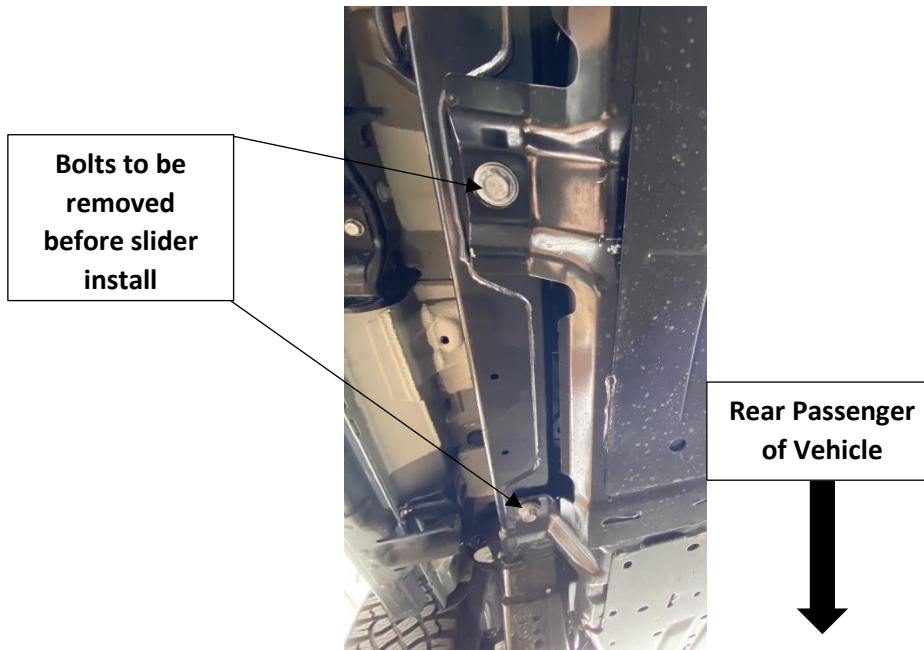

Figure 11

- 23) Now repeat steps 7-18 for the Passenger Side Rock Slider (#1).
- For step 10, ensure that the fuel tank skid plate or fuel tank straps are being re-installed on top of the slider frame plate using the same M12 x 40mm bolt (#11).
 - PLEASE NOTE:** the OEM fuel tank bolts can be re-used in place of the provided M12 x 40mm (#11) hardware if desired.
- 24) This concludes the installation of the RCI 21+ Ford Bronco 4 Door Rock sliders!

Share your new install with us on social media!
We love seeing our products out in the wild!

www.rcimetalworks.com

sales@rcioffroad.com

970-797-3089

REV: 1 | 09/29/2022

Created: GM



Disclaimer: The products sold by RCI Metalworks are intended for off-road use only, should not be modified, and are for use only on the vehicle(s) specifically stated. RCI Metalworks makes no warranties express or implied, including of fitness for a particular purpose or merchantability. RCI Metalworks will not be liable for any damages arising out of the use or misuse of its products. It is the customers' responsibility to ensure the products are safely and properly attached to the vehicle, and all products should be installed by trained professionals. We strive to maintain extremely high-quality standards; however, all RCI Metalworks products are individually handcrafted, may vary slightly, and may contain minor imperfections. Due to the nature of raw aluminum, the material may have minor scratches and other blemishes caused by the manufacturing process, especially on the back side of product. RCI Metalworks is constantly seeking to improve its products and reserves the right to make changes to any product.

APPENDIX A:

Additional Mounting Bracket Installation Instructions for 21+ Broncos Without Necessary Mounting Locations

- 1) **PLEASE NOTE:** This process requires calling RCI to receive an additional adaptor bracket to complete the bolt-on installation. If you would prefer to drill holes in the frame, please reference Appendix B for additional instructions.
- 2) Additional mounting brackets will come with four (4) extra 5/16" Washers, four (4) M8 Lock Nuts, and two (2) M8 x 45mm Bolts.
- 3) Follow the original install guide from Step 1 skipping Steps 6,12
- 4) Once the sliders are installed in place. Collect the appropriate bracket for each slider (D-driver, P-passenger).
- 5) Hold the bracket in place as depicted in Figure 12 and begin threading the M8 x 45mm bolt with one (1) 5/16" washer in the center hole of frame where the speed clip plate was installed earlier.
- 6) Collect two (2) of the M8 x 30mm Bolts and four (4) 5/16" Washers from the original hardware kit along with two (2) M8 Lock Nuts. Install these through the two openings towards the center of the vehicle in the following order: M8 x 30mm Bolt - 5/16" Washer - Vehicle Frame - 5/16" Washer - M8 Lock Nut.
- 7) Repeat Steps 4-6 for the opposite side of the vehicle.
- 8) Fully tighten all hardware to complete installation.

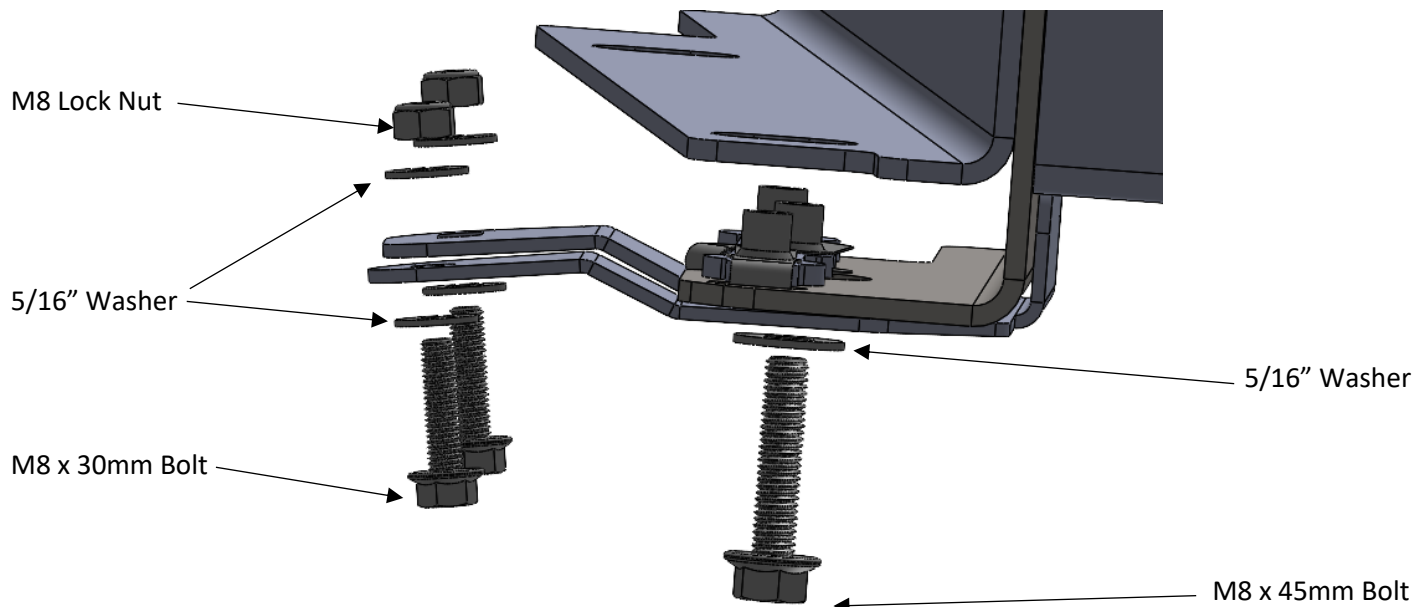

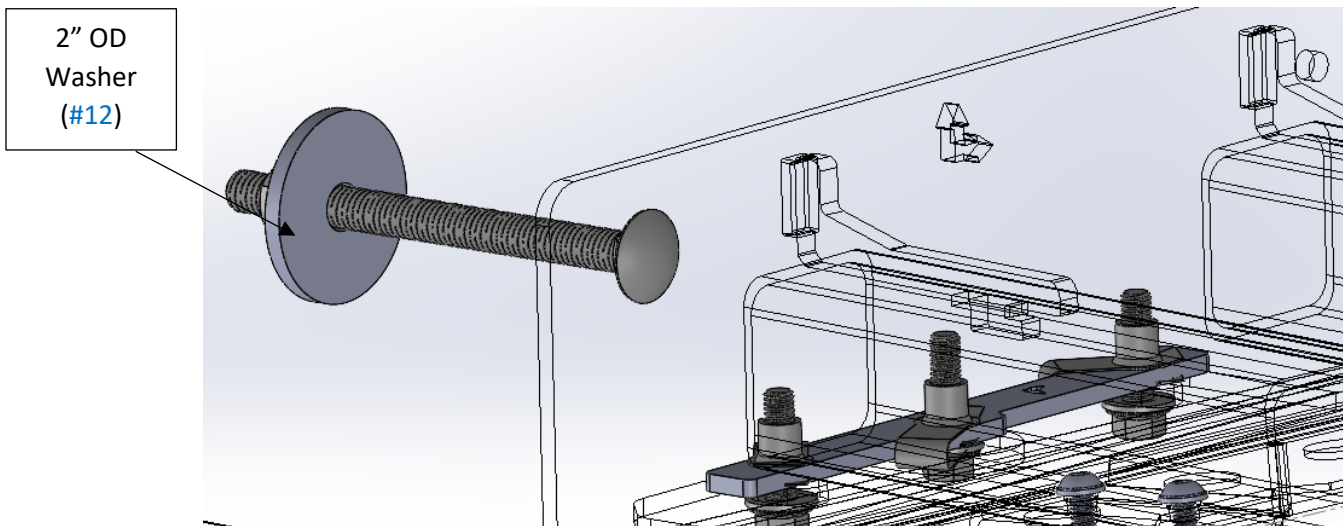

Figure 12 Correct Installation of Mounting Bracket

APPENDIX B:

Frame Drilling Installation Instructions for 21+ Broncos Without Necessary Mounting Locations

- 1) **PLEASE NOTE:** This installation process will require drilling to ensure proper mounting and fitment of the sliders.
 - a. A 1/2" drill bit and black paint will be needed for this process.
- 2) Begin by completing steps 2,3,8, and 9 to clear the frame of all side steps/sliders, brake line attachments, and wiring harness attachments.
- 3) Next, lift one of the Rock Sliders (#1) into position with the smaller frame plate towards the front of the vehicle. Begin threading the two (2) M12 bolts (#11) into the bottom of the frame centering the mounting slots on the frame with the threaded holes. The use of a floor jack, stool, or a helping hand is recommended until fasteners are installed.
- 4) Fully tighten both M12 bolts ensuring that the slider is tight with the frame of the vehicle.
- 5) Install one (1) 7/16" x 5" Carriage Bolt (#3) with the threads facing the inside of the vehicle through the square mounting hole. On the opposite side of the frame install the 2" OD Washer (#12), 7/16" Split Lock Washer (#5), and 7/16" Hex Nut in that order. Fully tighten the hex nut so that the front frame plate is flush with the frame of the truck.



- 6) From the bottom side of the frame, locate the mounting holes on the small front slider frame plate and mark the location to be drilled using a center punch or a marker. Reference the figure below.

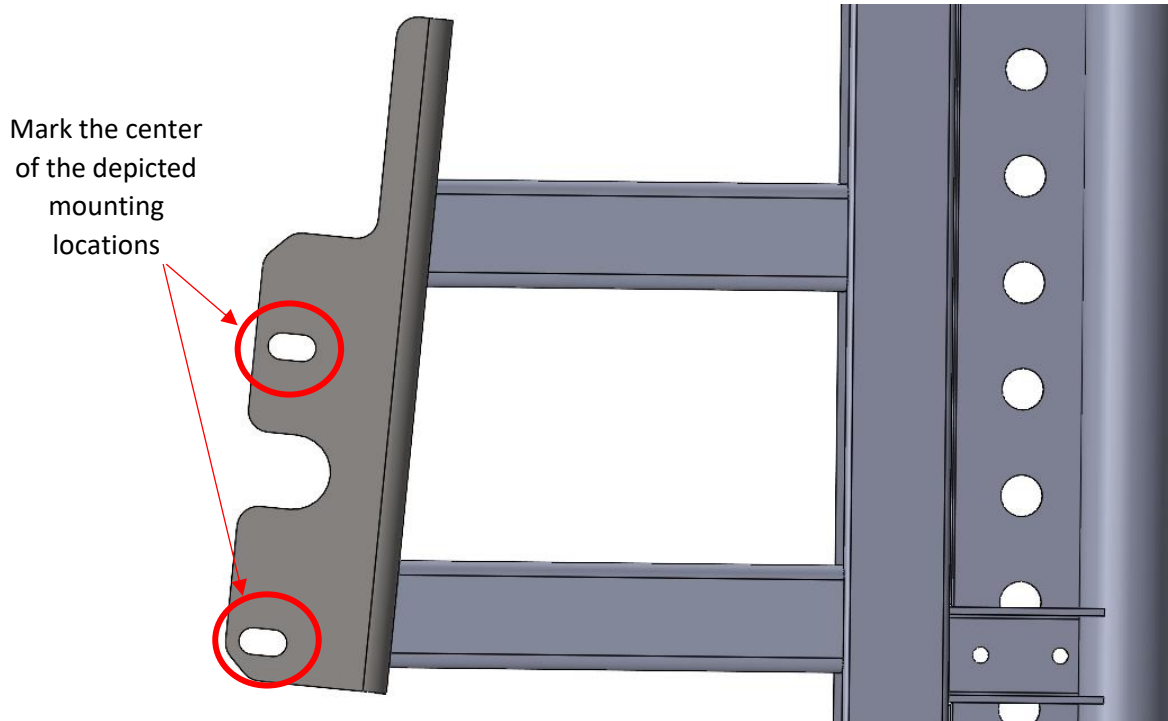

- 7) Remove all hardware securing the slider and set the slider aside before drilling.
- 8) Begin drilling out the required mounting holes finishing with a 1/2" drill bit. It works best to start with a smaller bit (around 1/4") then step up to the final size.
- 9) Once both holes are drilled, coat the bare metal with paint to prevent rust.
- 10) Repeat Steps 1-10 in Appendix B for the opposite side of the vehicle.
- 11) After the 4 mounting holes are drilled out (2 per side) continue the installation process with Step 2 of the install guide.