

# RCI FORD BRONCO TRANSMISSION SKID PLATE INSTALLATION GUIDE

\*\*This install guide is applicable to our Ford Bronco Transmission Skid Plate ONLY\*\*

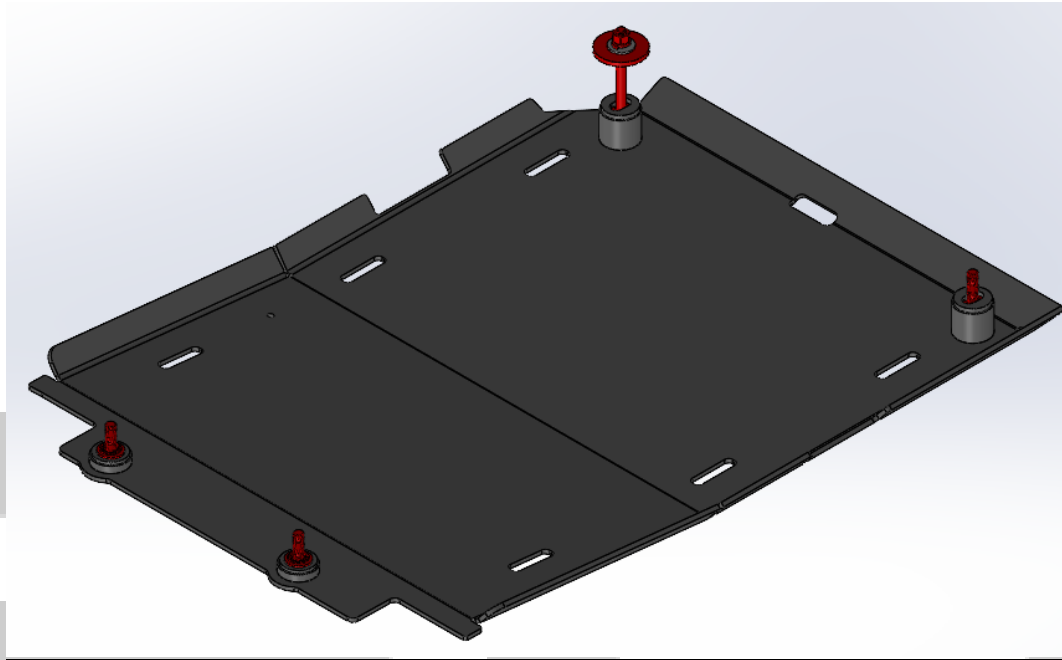

## TOOLS REQUIRED:

Description
15mm and 9/16" Socket Wrench and Socket Set
Box-End Wrenches

## INCLUDED HARDWARE:

Item	Description	QTY
H1.	3/8" Washer	7 ea.
H2.	M10 X 35mm Flanged Bolt	3 ea.
H3.	3/8" Retaining Washer	2 ea.
H4.	3/8" Nut	1 ea.
H5.	3/8" Split Lock Washer	1 ea.
H6.	3/8" x 3.5" Hex Bolt	1 ea.
H7.	Full Moon Washer	1 ea.

## INCLUDED COMPONENTS:

Item	Description	QTY
C1.	Bronco Transmission Skid Plate	1 ea.

## INSTALLATION STEPS:

- 1) Begin by unpacking and removing all components and hardware. Please verify that all hardware, components, and mounting components are present. Please reference your original order invoice and verify all items are accounted for.
  - a. Please note that our Bronco Transfer Case skid plate mounts closer to the vehicle and “above” our Bronco Transmission skid plate. If installing both, please install the Transfer Case skid plate before installing the Transmission skid plate.
  - b. If installing on a Bronco with the optional bash guards package, uninstall the factory transfer case bash guard before installing our Transfer Case skid plate.
- 2) Install a set of 3/8” washers(4), 3/8” retaining washers(2) and M10x35mm bolts(2) in the front-most mounting locations of the Transmission skid plates. As shown, the order of the hardware will be: bolt, washer, through skid, washer, retaining washer.

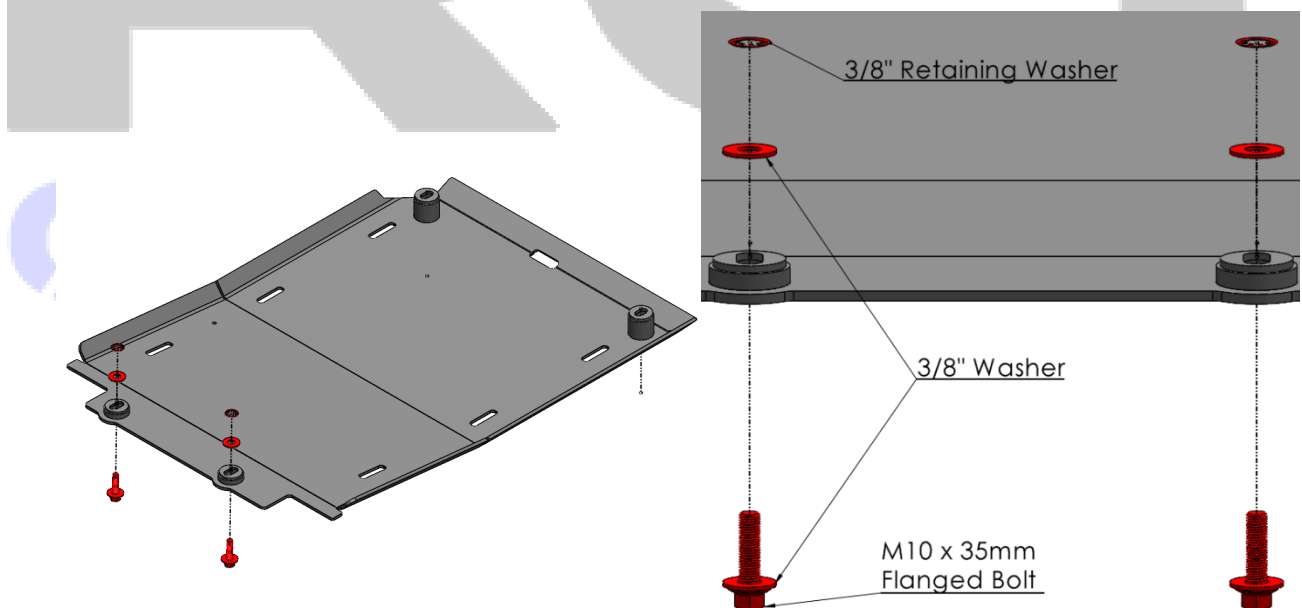

- 3) Align the front of the Transmission skid plate with the front vehicle crossmember. Thread the bolts into the crossmember until secure but do not tighten; the skid plate will need to be able to move slightly to achieve proper alignment with the rear crossmember.

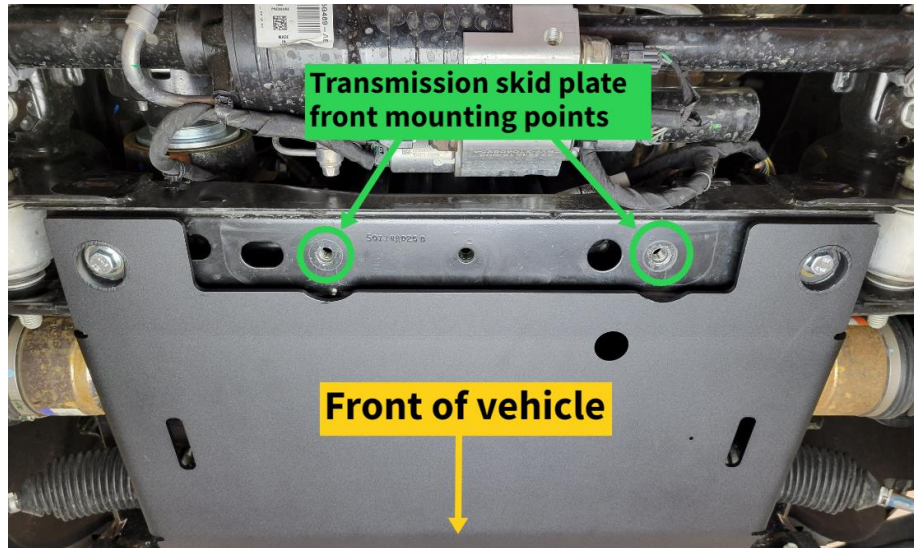

- 4) Adjust the Transmission skid plate to align with the mounting locations present on the central factory crossmember.
- 5) Install the remaining hardware through the mounting points towards the rear of the Transmission skid plate and into the central factory crossmember mounting locations. Tighten bolts.

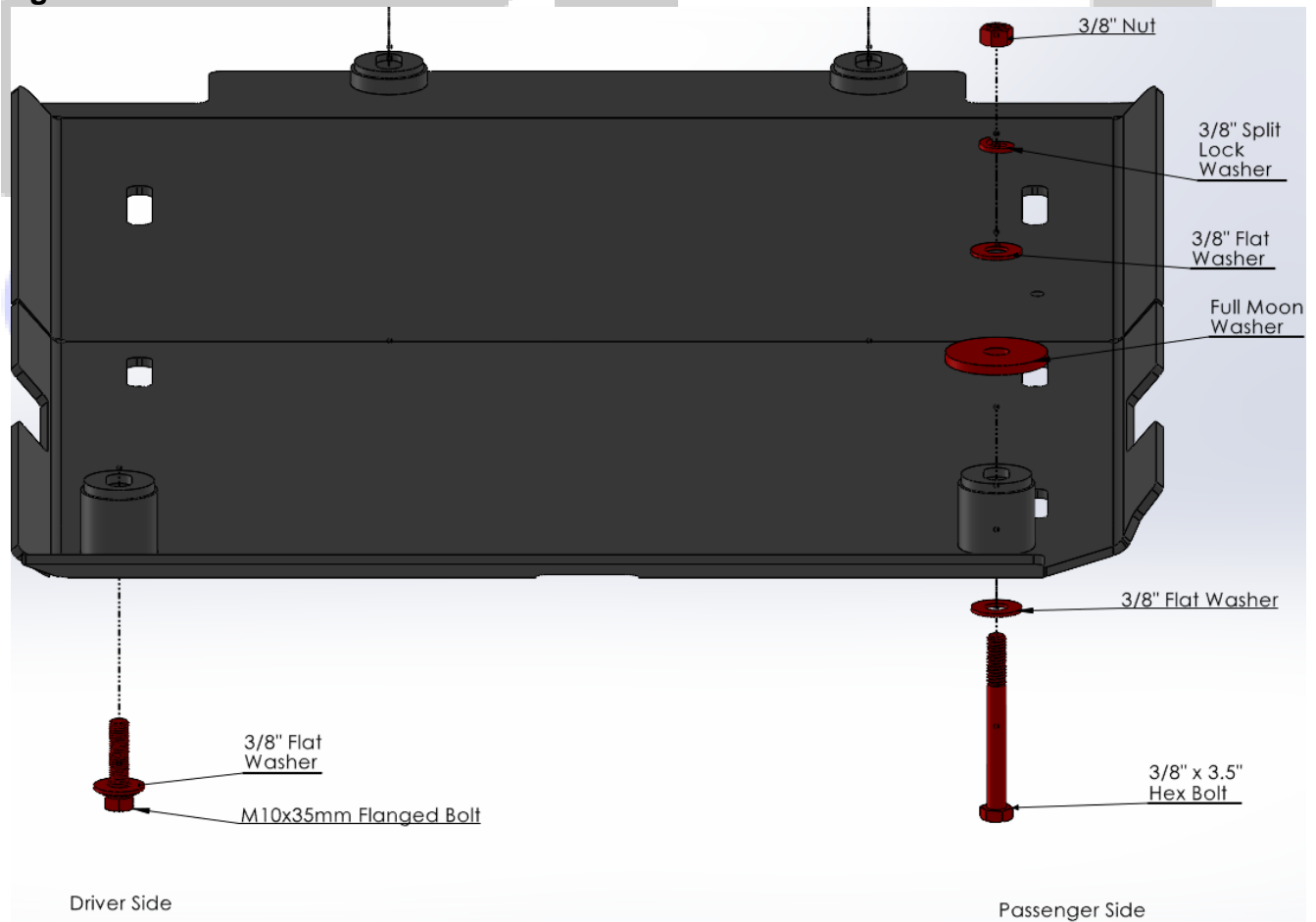

- a. If installing the RCI Bronco Transmission skid with an RCI Bronco Engine and Secondary skid plate, please loosely mount the Bronco Engine and Secondary

**skid plates(refer to Bronco Engine and Secondary install guide) and align the Secondary and Transmission skids before proceeding.**

- 6) Tighten the front hardware installed in step 3.**
- 7) Congratulations! Installation of your new RCI Ford Bronco Transmission Skid Plate is now complete!**

**RCI**  
**OFF ROAD**

**Share your new install with us on social media!**  
**We love seeing our products out in the wild!**

**RCI**  
**OFF ROAD**

**[www.rcimetalworks.com](http://www.rcimetalworks.com)**

**[sales@rcioffroad.com](mailto:sales@rcioffroad.com)**

**970-797-3089**

REV: 1 | 01/26/2022

Created: KL



---

Disclaimer: The products sold by RCI Metalworks are intended for off –road use only, should not be modified, and are for use only on the vehicle(s) specifically stated. RCI Metalworks makes no warranties express or implied, including of fitness for a particular purpose or merchantability. RCI Metalworks will not be liable for any damages arising out of the use or misuse of its products. It is the customers' responsibility to ensure the products are safely and properly attached to the vehicle, and all products should be installed by trained professionals. We strive to maintain extremely high quality standards; however, all RCI Metalworks products are individually handcrafted, may vary slightly, and may contain minor imperfections. Due to the nature of raw aluminum, the material may have minor scratches and other blemishes caused by the manufacturing process, especially on the back side of product. RCI Metalworks is constantly seeking to improve its products and reserves the right to make changes to any product.