

RCI Bronco A-arm Skid Plate Install Guide

Welded to Item #1

ITEM NO.	PART NUMBER	QTY.
1	21+ Bronco A-arm Skid	2
2	21+ Bronco A-arm Cover plate	2
3	21+ Bronco A-arm Top mount	2
4	3/8 x 1.25" Carriage Bolt	2
5	3/8 Washer	2
6	3/8 Split Washer	2
7	3/8 Hex Nut	2

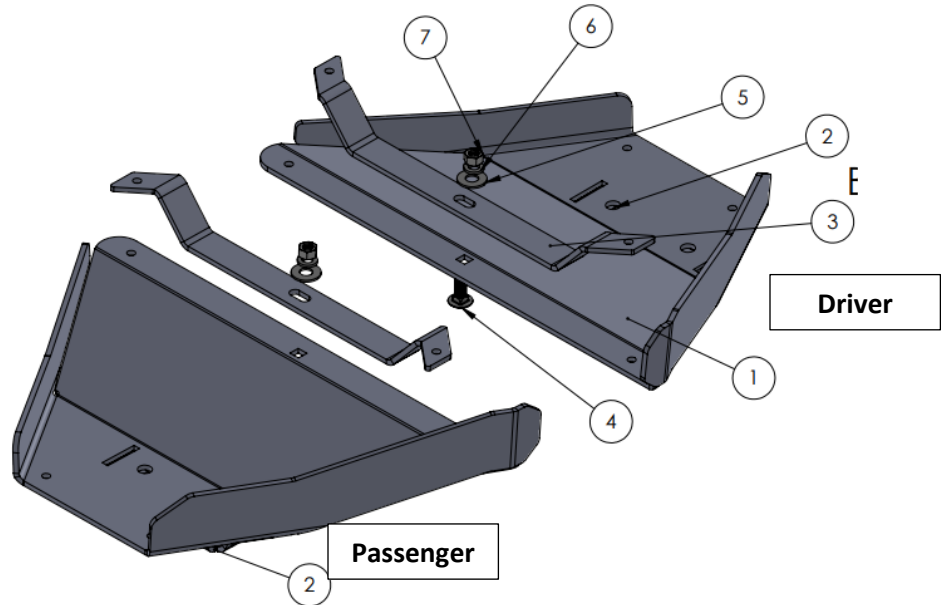

Figure 1: Assembly with hardware

1. Begin by unpacking and removing all components and hardware. Please verify that all hardware, components, and mounting components are present. Please reference your original order invoice and verify all items are accounted for.
2. Start on the passenger side of the vehicle and remove the two OEM shock bolt nuts using a 18mm socket. These are located under the vehicles lower control arms.
 - a. **PLEASE NOTE:** If a vehicle lift is being used for this install the front tires will need to be supported before removing the shock bolts. RCI recommends using a tall corkscrew or transmission jack for support.

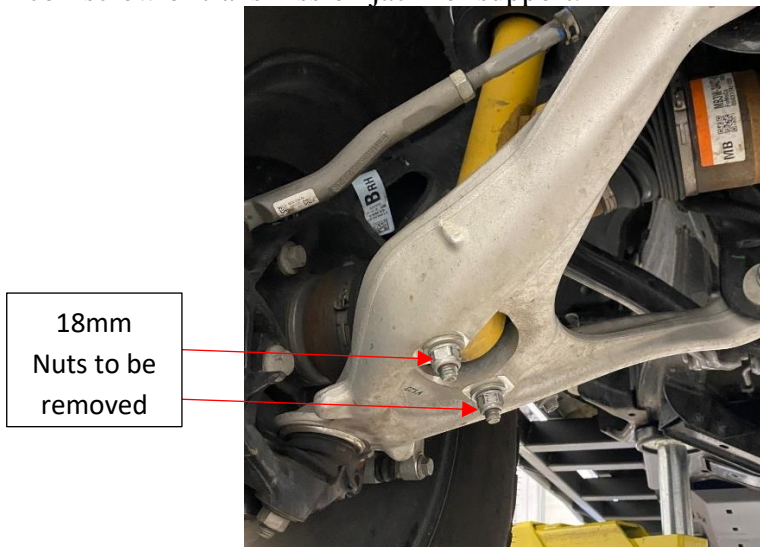

Figure 2: Lower Control Arm Nut Location

- Once the nuts are removed install the passenger A-arm skid plate by sliding the OEM bolts through the holes in the A-arm skid plate. While holding the A-arm skid in place hand thread the OEM 18mm nuts until the skid plate is supported.



Figure 3: Image Represents Reinstalled 18mm Nuts

- Use a 18mm deep socket to snug down the two OEM bolts before installing the top mount (#3).
- Collect one of the Bronco A-arm Top Mounts (#3), one 3/8" x 1.25" Carriage Bolts (#4), one 3/8" Washer (#5), one 3/8" Split Washer (#6), and one 3/8" Hex Nut (#7). Install the hardware as depicted in Figure 4.
 - NOTE: The Bronco A-arm Top Mounts (#3) need to be installed with tips of the winged flanges point towards the outside of the vehicle. Reference Figure 5.

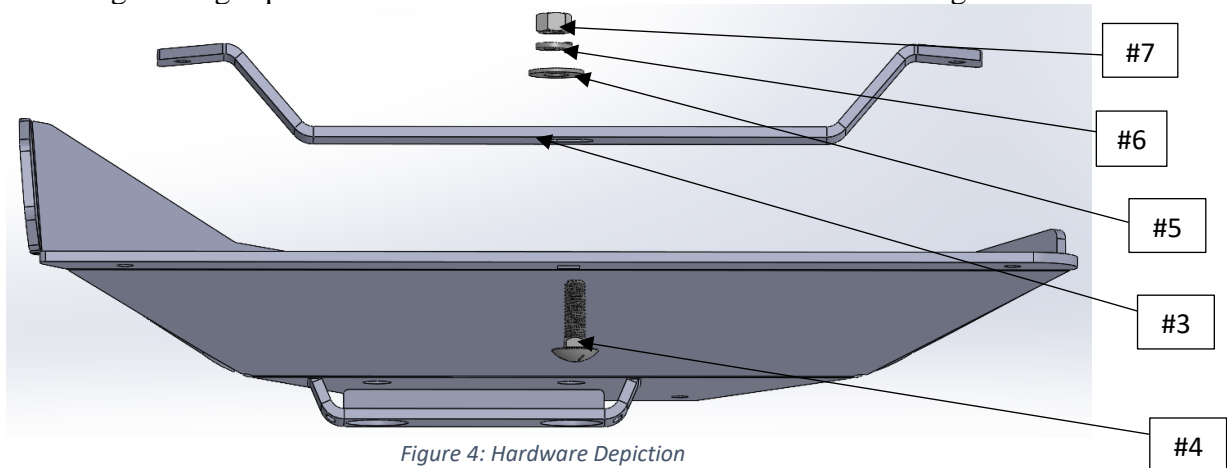

Figure 4: Hardware Depiction

Top Mount
wings facing
outside of
vehicle.

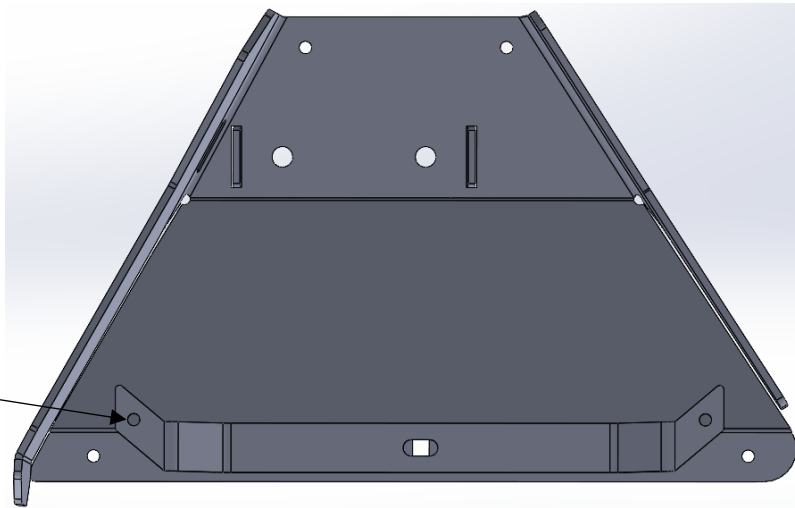

Figure 5: Correct Orientation of Top Mount

6. Once loosely installed, tighten the 3/8" Hex Nut (#7) until the Top Mount (#3) is contacting the Bronco A-arm Skid Plate (#1). Tighten the 18mm nuts in Step 4 to manufacturers recommendation.
7. Repeat Steps 2-6 for the driver side of the vehicle.
8. Ensure all hardware is tight after both A-arm skid plates are installed.

Enjoy your new RCI Bronco A-arm Skid Plates!

Share your new install with us on social media!

We love seeing our products out in the wild!

www.rcimetalworks.com

sales@rcioffroad.com

970-797-3089



Disclaimer: The products sold by RCI Metalworks are intended for off-road use only, should not be modified, and are for use only on the vehicle(s) specifically stated. RCI Metalworks makes no warranties express or implied, including of fitness for a particular purpose or merchantability. RCI Metalworks will not be liable for any damages arising out of the use or misuse of its products. It is the customers' responsibility to ensure the products are safely and properly attached to the vehicle, and all products should be installed by trained professionals. We strive to maintain extremely high quality standards; however, all RCI Metalworks products are individually handcrafted, may vary slightly, and may contain minor imperfections. Due to the nature of raw aluminum, the material may have minor scratches and other blemishes caused by the manufacturing process, especially on the back side of product. RCI Metalworks is constantly seeking to improve its products and reserves the right to make changes to any product.