

RCI 4DR Bronco Pinch Weld Cover Install +Guide

ITEM NO.	PART NUMBER	QTY.
1	M6 x 1 x 20mm Button Head Screw	16
2	M6x1mm Lock Nut	12
3	1/4" Black Flat Washer	28
4	4 Door Bronco Front Pinch Weld Cover	2
5	4 Door Bronco Front Pinch Weld Cover	2

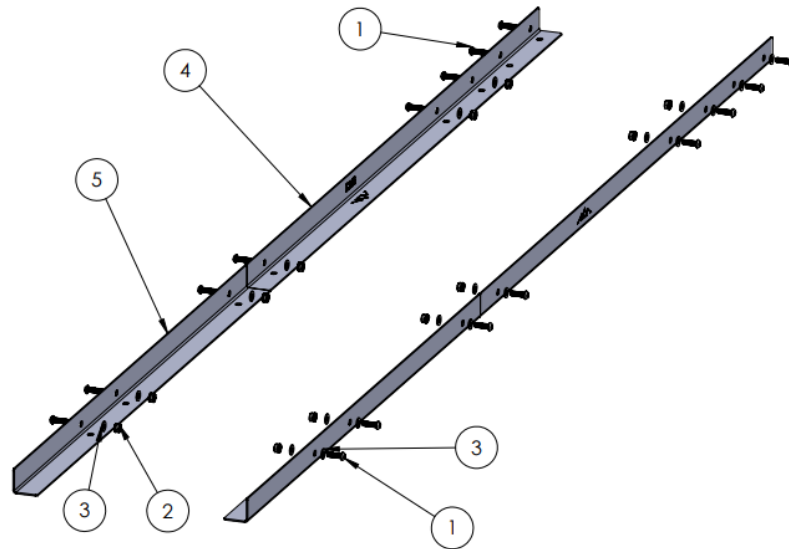

Figure 1: Assembly with hardware

Bronco Pinch Weld Covers can be installed on either side of the vehicle.

1. Begin by unpacking and removing all components and hardware. Please verify that all hardware, components, and mounting components are present. Reference your original order invoice and verify all items are accounted for.
 - a. Remove all OEM rock rails or side steps from vehicle before install.
 - b. PLEASE NOTE:** The Bronco Pinch Weld Covers are not compatible with side steps or rock guards that use the pinch weld for mounting.

Example of rock rail mounting through pinch weld



Figure 2

2. Remove the two frontmost bolts from the pinch weld using a 10mm socket. These are located behind the front tires on either side.



Figure 3: Frontmost pinch weld bolts

3. Starting with driver side of the vehicle, obtain one of the Bronco Front Pinch Weld Covers (#4) and align it with the front 5 holes on the pinch weld. For the driver side the RCI logo will be facing outwards.



Figure 4: Driver Side Front Pinch Weld Cover

4. Collect 5 of the M6 x 20mm button head screws (#1), ten (10) of the 1/4" washers (#3), and three (3) lock nuts (#4). Install the three (3) of the M6 x 20mm button head screws with washers in the 3 rearmost holes as depicted in figure 5. Install the two (2) M6 screws (#5) with washers in the frontmost holes using the OEM threads.

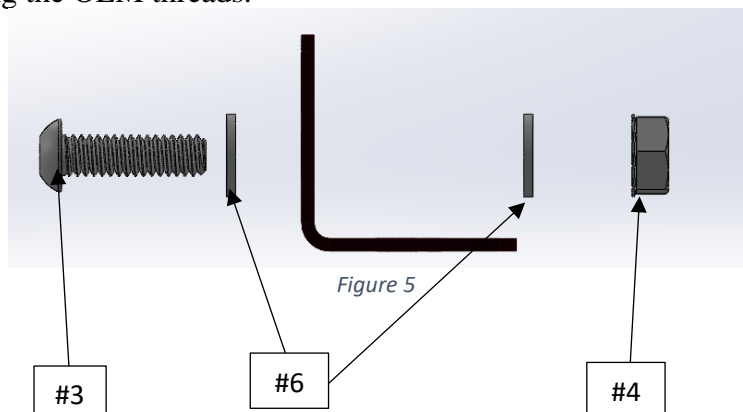

Figure 5

5. Repeat Step 4 with one of the Bronco Rear Pinch Weld Covers (#2) by aligning the three holes with the holes on the pinch weld. Use 3 M6 x 20mm button head screws (#1), 6 1/4" washers (#3), and three (3) lock nuts (#4). Install the hardware as depicted in Figure 5.



Figure 6: Correct orientation of Driver Side Pinch Weld Covers

6. Repeat Steps 3-5 for the passenger side of the vehicle.
 - a. **PLEASE NOTE:** For the passenger side of the vehicle the mountain logo will be facing outwards.
7. Once Driver and Passenger front and rear pinch weld covers are installed, align the two covers to users liking and snug down all hardware.

Enjoy your new RCI 4DR Bronco Pinch Weld Covers!

Share your new install with us on social media!

We love seeing our products out in the wild!

www.rcimetalworks.com

sales@rcioffroad.com

970-797-3089



Disclaimer: The products sold by RCI Metalworks are intended for off-road use only, should not be modified, and are for use only on the vehicle(s) specifically stated. RCI Metalworks makes no warranties express or implied, including of fitness for a particular purpose or merchantability. RCI Metalworks will not be liable for any damages arising out of the use or misuse of its products. It is the customers' responsibility to ensure the products are safely and properly attached to the vehicle, and all products should be installed by trained professionals. We strive to maintain extremely high quality standards; however, all RCI Metalworks products are individually handcrafted, may vary slightly, and may contain minor imperfections. Due to the nature of raw aluminum, the material may have minor scratches and other blemishes caused by the manufacturing process, especially on the back side of product. RCI Metalworks is constantly seeking to improve its products and reserves the right to make changes to any product.