

RCI FORD BRONCO ENGINE AND SECONDARY SKID PLATE INSTALLATION GUIDE

****This install guide is applicable to our Ford Bronco Engine and Secondary Skid Plate ONLY****



TOOLS REQUIRED:

Description
15mm and 9/16" Socket Wrench and Socket Set
Box-End Wrenches

INCLUDED HARDWARE:

Item	Description	QTY
H1.	3/8" x 1" Carriage Bolt	3 ea.
H2.	3/8" Washer	9 ea.
H3.	3/8" Split Lock Washer	3 ea.
H4.	3/8" Nut	3 ea.
H5.	M10 X 35mm Flanged Bolt	6 ea.

INCLUDED COMPONENTS:

Item	Description	QTY
------	-------------	-----

C1.	Bronco Engine Skid Plate	1 ea.
C2.	Bronco Secondary Skid Plate	1 ea.

INSTALLATION STEPS:

- 1) Begin by unpacking and removing all components and hardware. Please verify that all hardware, components, and mounting components are present. Please reference your original order invoice and verify all items are accounted for.
- 2) Secure the Secondary skid plate to the Engine skid plate using the included 3/8" X 1" carriage bolts(3), 3/8" washers(3), and 3/8" locknut(3). Please refer to the figures below for the correct orientation of the engine and secondary skid, as well as hardware orientation.

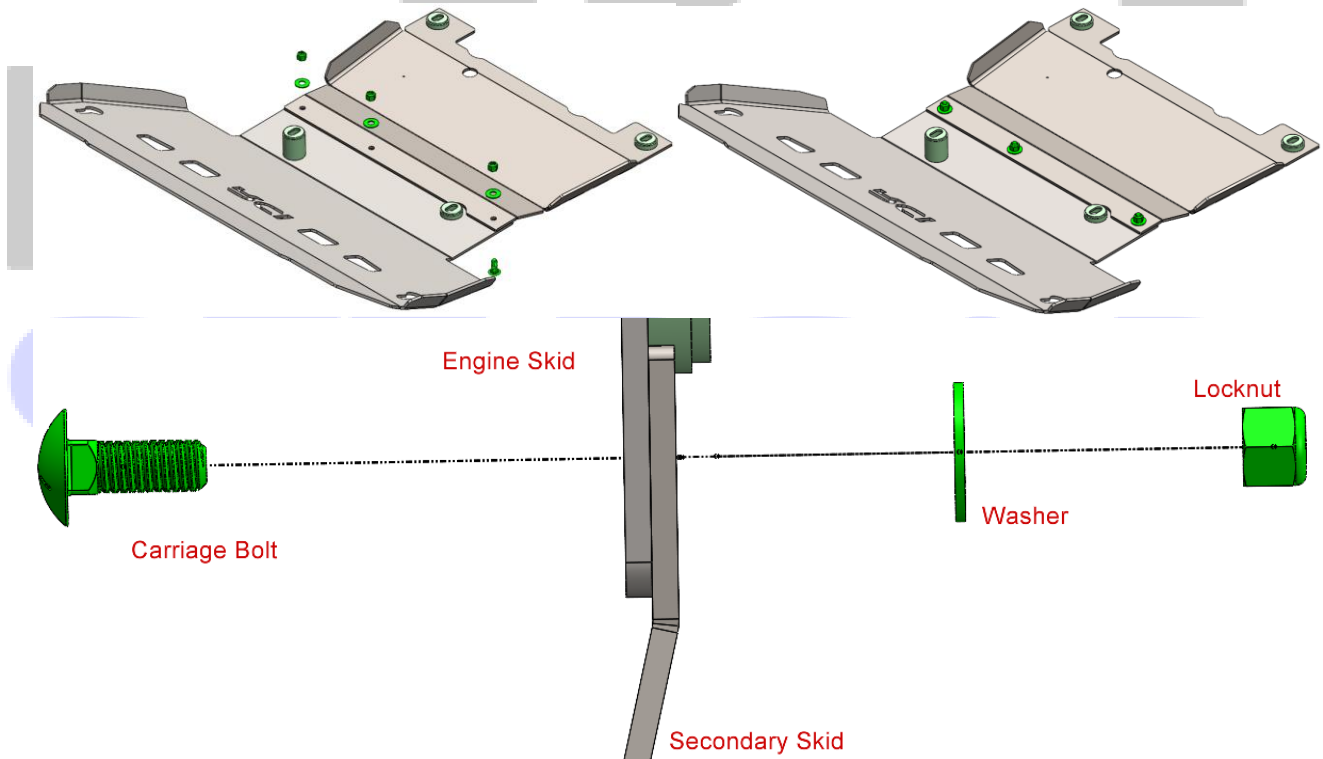

- 3) Remove the factory plastic air dam or steel bash guards from the front underside of the vehicle.
- 4) Install M10X35mm bolts(2) and 3/8" washers in the front-most factory locations. Leave approximately 1/2" of thread exposed between the vehicle chassis and washer.

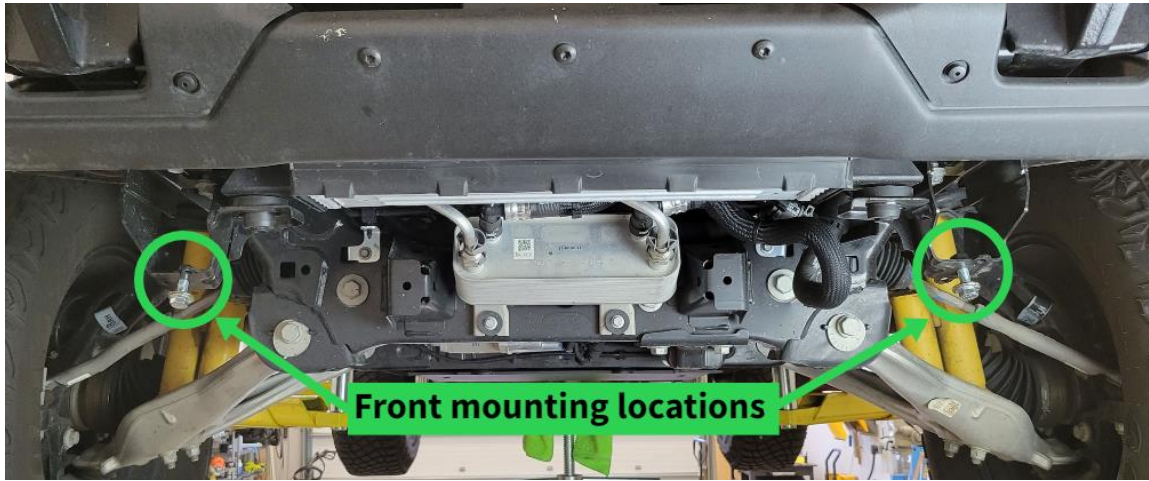

- 5) Lift the assembled Engine and Secondary skid package to their approximate final location. Pass the washer and bolt assembly installed in step 4 through the keyhole shaped cutouts at the front of the Engine skid. Lower the Engine and Secondary skid assembly, allowing it to rest on the front bolts and washers.



- 6) Lift the rear of the Secondary skid package until it contacts the vehicle chassis. Loosely install a set of 3/8" washers(2) and M10x35mm bolts(2) in the rear-most mounting points of the Secondary skid.

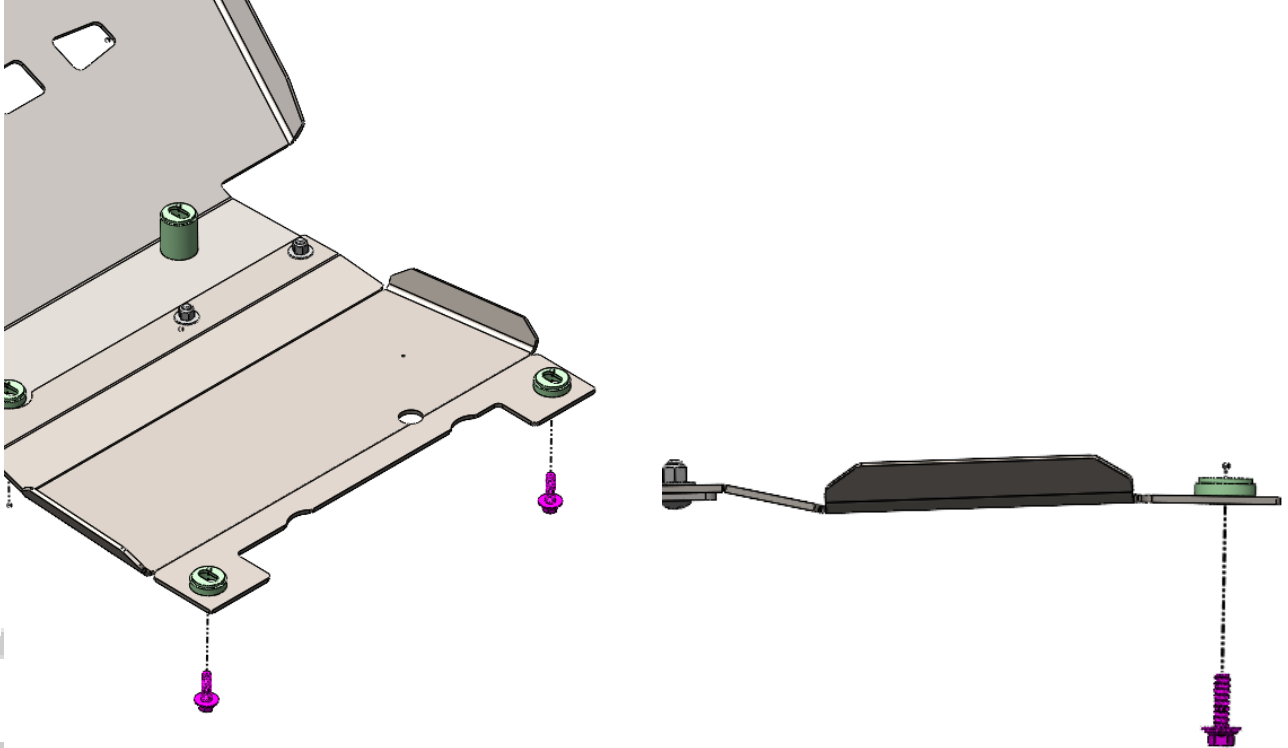

- 7) Install a set of 3/8" washers(2) and M10x35mm bolts(2) in the central mounting points of the assembly, just in front of the carriage bolts installed in step 2. Tighten.

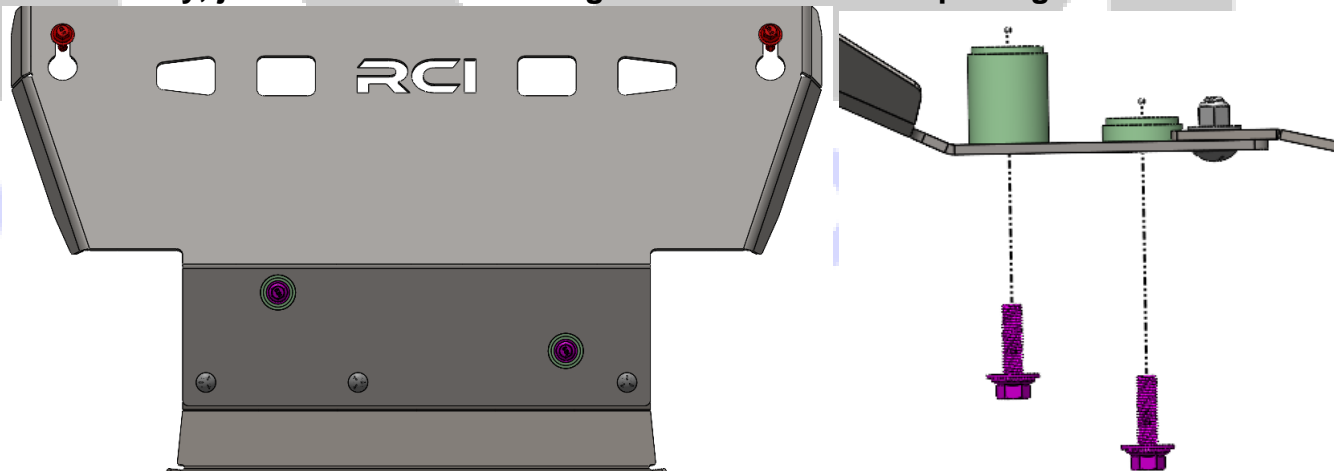

- a. If installing the RCI Bronco Engine and Secondary skid plate with an RCI Bronco Transmission skid, please loosely mount the Transmission skid(refer to Bronco Transmission install guide) and align the Secondary and Transmission skids before proceeding.
- 8) Tighten the rear bolts from step 6, followed by the front bolts from step 4.

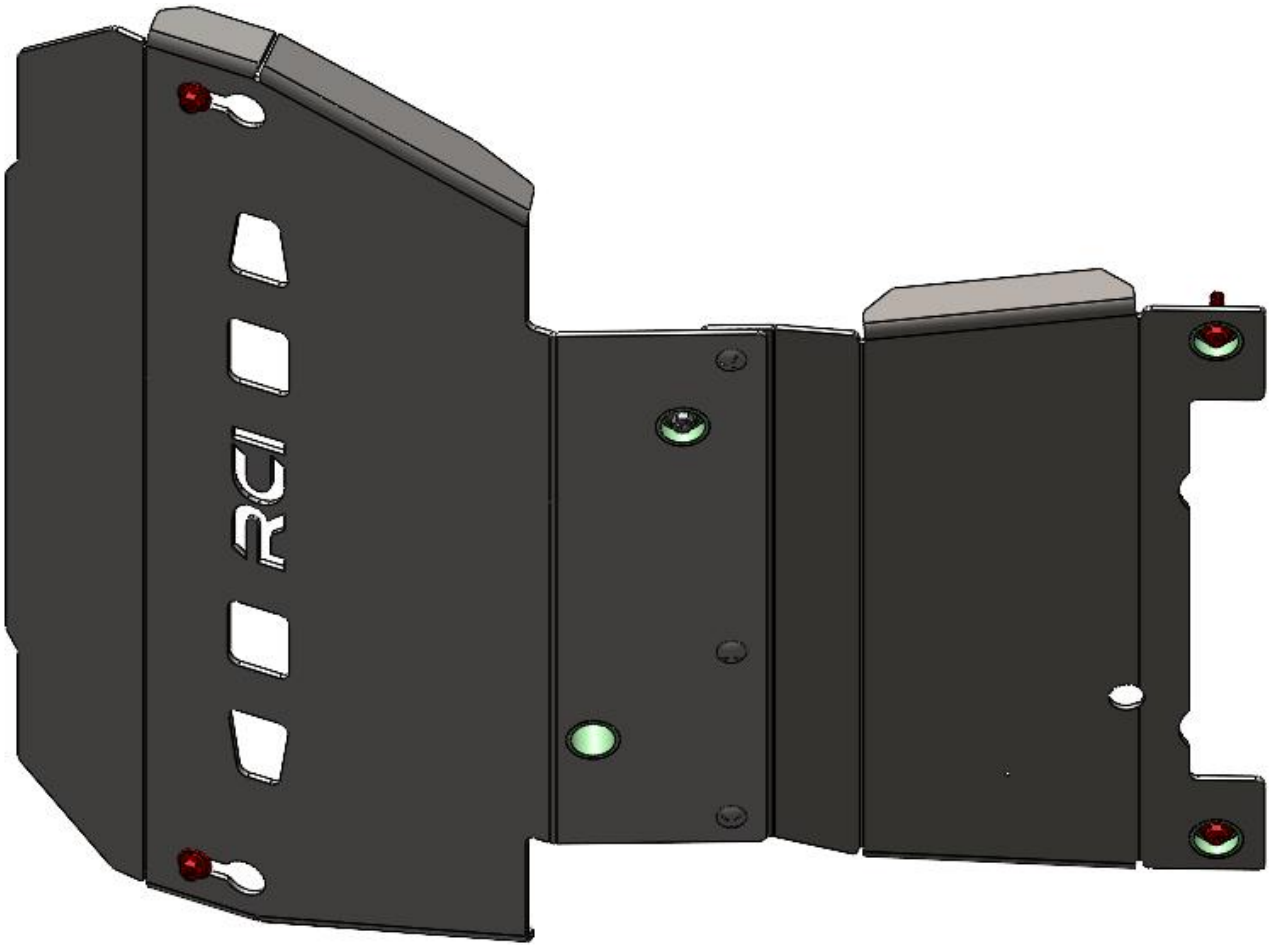

9) Congratulations! Installation of your new RCI Ford Bronco Engine and Secondary Skid Plate is now complete!

OFF ROAD

**Share your new install with us on social media!
We love seeing our products out in the wild!**

RCI
OFF ROAD

www.rcimetalworks.com

sales@rcioffroad.com

970-797-3089

REV: 1 | 01/26/2022

Created: AWM

